

DAVEY

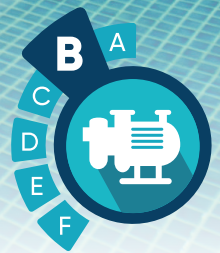

Smartphone control via
Davey Pool Pump app



SILENSOR[®] PRO by DAVEY

Model Number:
SP200BT

GUARANTEE
3 YEARS

APPLICATION

Ideal for pool filtration, water features, and pool & spa heating systems.

ENERGY EFFICIENT VARIABLE SPEED PUMP

FEATURES & BENEFITS

- **Bluetooth enabled** – To allow set and control filtration and speed cycles from your iOS or Android smartphone
- **Ability to cap peak flow, priming and backwash speeds** – Ideal for retrofit installations with sand filters
- **Super quiet** – Designed with a unique water cooled motor which captures noise and vibrations, allowing super quiet operation, rated down to 50dBa*. Your neighbours won't even know it's there
- **Backwash speed cycling technology** – For effective media cleaning and reducing waste water when backwashing
- **Loss of prime protection** – Minimises damage if the pump runs dry
- **Convenient** – Extra-large 4.5 litre leaf basket – less cleaning required

Variable Speed Pumps



SILENSOR[®] PRO by DAVEY

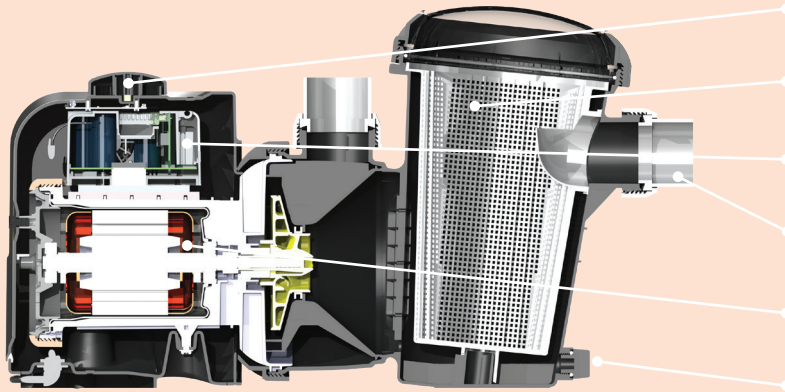

Bluetooth smartphone control via iOS or Android app

Variable Frequency Drive with selectable speed dial from 1500rpm to 3600rpm

Large Leaf Basket with easy to remove, clear lid

Loss of prime protection to protect the pump when there is no water inside the pump

Quality ABS quick coupling barrel unions for simple installation

High performance water cooled motor for super quiet, efficient use all year round

Drain plug enables quick draining of the casing for easy removal and maintenance

Made in Australia • CE

ELECTRICAL DATA

Voltage (V)	220 - 240
Supply frequency (Hz)	50/60
Maximum input power (W/hp)	128W/0.17hp @ Dial 1 524W/0.70hp @ Dial 5 1,126W/1.51hp @ Dial 10 Backwash: varies
Motor speed (rpm)	1,500 to 3,600
Standby power (W)	8
Backwash (rpm)	Variable speed
Enclosure class (IP)	45
Insulation Class	F
Power lead length	3m
Approval No.	SGS-180275-EA

OPERATING LIMITS

Max Water Temperature	40°C
Max Ambient Temperature	50°C
Sound Pressure Level	50dB*
Sound Power Level	70 dBa**

PERFORMANCE CURVES

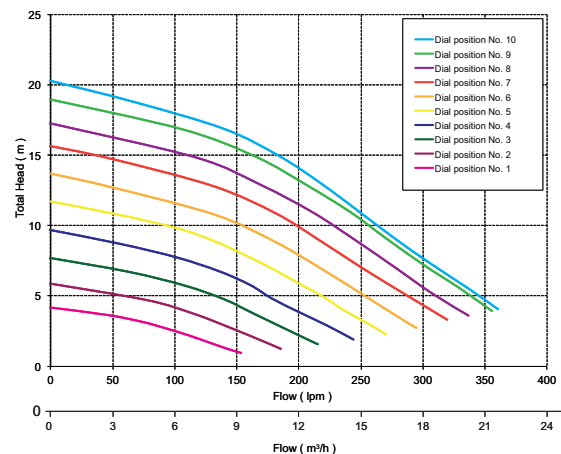

* Sound pressure level tested as per typical installation

** Sound power level tested to EN 17645

DIMENSIONS (mm)

Model	A	B	C	D	E	F	G	H	I	Mounting Holes Diameter	Inlet & Outlet	Net Weight (kg)
SP200BT	305	670	320	350	65	230	380	200	250	10	50/63	14



daveywater.com

This literature is not a complete guide to product usage. All images provided in this document are for illustration purposes only. Further information is available from your Davey Dealer, Davey Support Centre and from the relevant product Installation and Operating Instructions. Must be read in conjunction with the relevant product Installation and Operating Instructions and all applicable statutory requirements. Product specifications may change without notice. © Davey is a registered trademark of Davey Water Products Pty Ltd. © Davey Water Products Pty Ltd 2024.

