

BLUETOOTH ENABLED

SILENSOR[®] PRO
by DAVEY

VSD200

A PUMP LIKE
NO OTHER
NOW WITH BLUETOOTH[®]

APPLICATION

Ideal for pool filtration, water features,
and pool & spa heating systems



smartphone control via
Davey Pool Pump app



residential



pool pump

HIGH EFFICIENCY, SUPER QUIET, WATER COOLED DESIGN

- > **Bluetooth enabled** – To allow set and control filtration and speed cycles from your iOS or Android smartphone
- > **Ability to cap peak flow, priming and backwash speeds** – Ideal for retrofit installations with sand filters
- > **Super quiet** – Designed with a unique water cooled motor which captures noise and vibrations, allowing super quiet operation, rated down to 50dBa. Your neighbours won't even know it's there
- > **Backwash speed cycling technology** – For effective media cleaning and reducing waste water when backwashing
- > **Loss of prime protection** – Minimises damage if the pump runs dry
- > **Convenient** – Extra-large 4.5 litre leaf basket – less cleaning required



Depend on Davey

DAVEY

SilensorPro Bluetooth® VSD200 Pool Pump

Bluetooth smartphone control
via iOS or Android app

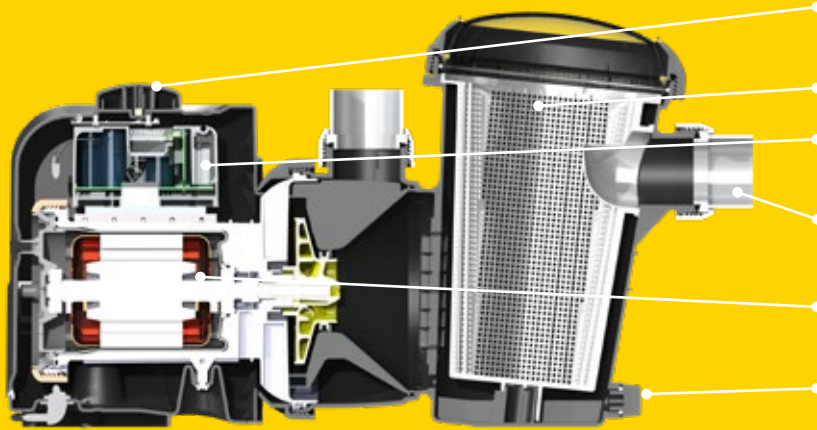

- Variable Frequency Drive** with selectable speed dial from 1500rpm to 3600rpm
- Large Leaf Basket** with easy to remove, clear lid
- Loss of prime protection** to protect the pump when there is no water inside the pump
- Quality ABS quick coupling barrel unions** for simple installation
- High performance water cooled motor** for super quiet, efficient use all year round
- Drain plug** enables quick draining of the casing for easy removal and maintenance

Made in Australia • CE

ELECTRICAL DATA

Voltage (V)	240
Supply frequency (Hz)	50/60
Motor input power (W/hp)	116W/0.16hp @ Dial 1 488W/0.65hp @ Dial 5 1,000W/1.34hp @ Dial 10
Motor speed (rpm)	1,500 to 3,600
Backwash (rpm)	Variable
Enclosure class (IP)	45
Insulation class	F
Power lead length	3m
Approval No.	SGS-180275-EA

HYDRAULIC PERFORMANCE

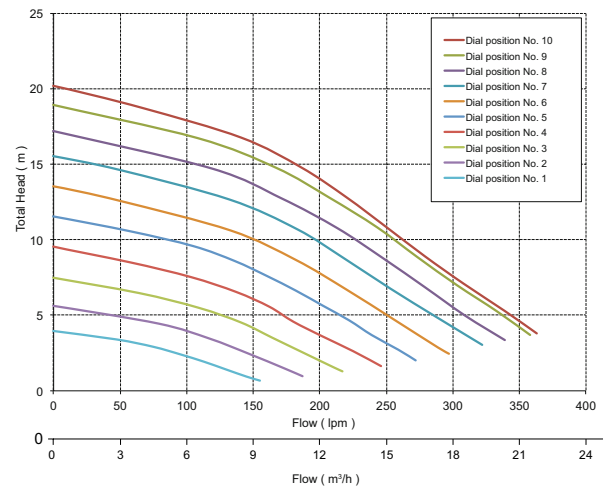

OPERATING LIMITS

Max. water temperature	Max. ambient temperature	Noise level (AS 5102.2)
40°C	50°C	50 dBa (at Speed 1)

DIMENSIONS (mm)

Model	A	B	C	D	E	F	G	H	I	Mounting Holes Diameter	Inlet/Outlet PVC	Net Weight (kg)
SP200BT	305	670	320	350	65	230	380	200	250	10	50	14

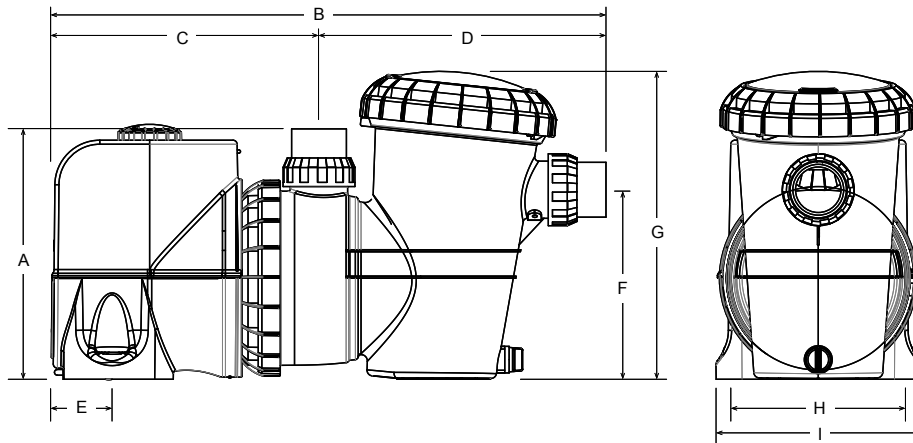

daveyeurope.eu | info@daveyeurope.eu

This literature is not a complete guide to product usage. Further information is available from your Davey Dealer, Davey Support Centre and from the relevant product Installation and Operating Instructions. Must be read in conjunction with the relevant product Installation and Operating Instructions and all applicable statutory requirements. Product specifications may change without notice. © Davey is a registered trademark of Davey Water Products Pty Ltd. © Davey Water Products Pty Ltd 2018.

DAVEY

Depend on Davey