

 *Plastica*

# NAZCA WOODEN POOLS WITH METAL BRACES

Self build installation guide for Nazca Wooden Pools  
4m x 2m, 8m x 2m, 8m x 4m, 6m x 4m and 6m x 3m



[www.woodenpools.net](http://www.woodenpools.net)

## Contents

Introduction . . . . .	3
Recommendations for storage after delivery . . . . .	3
Natural Timber Characteristics . . . . .	4
Preparing the Base . . . . .	5
Building the Concrete Base . . . . .	6
Total or Partial In-ground Installation . . . . .	7
Building the Timber Structure. . . . .	9
Understanding the Wooden Wall Profiles. . . . .	9
Building the Wall Structure . . . . .	10
Building a Wooden Step Ladder. . . . .	16
Installing the Wooden Top Ring-Beam and Support Blocks . . . . .	18
Installing the Vertical Supports. . . . .	21
Installing the End-capping Channel . . . . .	25
Fixing the Top Shelving . . . . .	26
Installing the Liner Lock . . . . .	28
Fitting Inlets/Low-level Suction or Vacuum Point	29
Laying the Felt Underlay. . . . .	30
Foam Wall Protection . . . . .	31
Installing the Liner . . . . .	32
Installing the Pipework and Equipment . . . . .	39
Installing Low Level Suction/Inlets . . . . .	40
Installing the Skimmer(s) . . . . .	41
Installing the Stainless Steel Ladder . . . . .	42
Tool Kit . . . . .	44
Warranty. . . . .	45
Nazca Schematic Plans. . . . .	46-51

# Introduction

A video is available on our wooden pools website [www.woodenpools.net](http://www.woodenpools.net). The video shows a project from start to finish and is an informative guide to compliment this book. For detailed instructions please primarily use this book. You are advised to watch the entire video and completely read this book before starting your project.

In the event of any problems please contact your dealer immediately. Warranty claims may be affected if there is a delay in reporting a problem or if these instructions have not been followed.

**Tools required are listed at the end of this book**

## Recommendations for storage after delivery

- Do not store the timber in direct sunlight or under a dark cover as this may cause distortion which will make installation extremely difficult.
- Assemble the structure as soon as possible after receipt.
- Assemble the structure in one go, preferably in the morning while temperatures are cooler.
- If a timber product must be stored, then use a cool well-ventilated place, sheltered from the rain and sun.
- Components that are damaged, cracked or distorted due to incorrect storage and/or handling will not be covered by the warranty.
- **Please ensure the liner is stored in a warm environment before installation.**

In the pre-assembly period, wood is sensitive to variations in temperature and humidity. It is therefore necessary that you take precautions immediately after delivery.

Wood is a living material and once cut the appearance of cracks, slight movements or changes in colour are normal and the planks (except in extreme circumstances) do not need replacing. The planks will have been recently treated and may be still moist when delivered.

In the case of rapid temperature change these planks can dry very quickly and lose one or two millimetres in height. This might give the impression that the planks are lifting but they are actually shrinking, whilst in cooler wet conditions the wood may expand back to its original size. This is completely normal.

**Please note: some of the images in this installation manual may be from another type of pool and are being used for illustration purposes only.**

# Natural Timber Characteristics

Whilst we try to ensure that our timber products reach you in perfect condition, we are dealing with a natural material and there are many characteristics which can arise. These are completely normal and have no detrimental effect on the product.

We manufacture our products so that most natural characteristics are inside where you wouldn't see them, or the plank may be reversible so it can be used either way around.



**Shake** appears like a series of splits. With a timber section of this size you will always encounter some degree of this (usually on one side). This does not affect the strength of the product and you will find the shake opens in continued warm weather and then closes when the weather is wet and cooler or there is a lot of moisture in the air.



**Pith** is similar to the above characteristics and quite often found along side each other.



**Knots & Sap** are typically found in timber as shown. These are not generally an issue and can actually be beneficial, relieving stress points in timber. These can add character to the product. Sap can also be present and can be carefully scraped off with an appropriate tool.



**Cupping** is mainly caused by the treatment of the timber. Where timber is kiln dried and then pressure treated it can cause cupping. Although we limit this, the best way to counteract it is; as you build the walls of your product, have one plank with the growth rings facing one way and the next with the rings facing the opposite way (**counter cupping**). This is only possible on square or rectangular products as the planks are reversible. On octagonal products if you have a problematic plank try it in another wall position to see where it will fit best.



Please note we cannot accept returns for natural characteristic complaints (except in extreme circumstances, at the supplier's discretion). This includes planks which may arrive damp or containing mould residue (this is not a lasting or detrimental factor). Any damage caused by poor handling or failure to follow instructions is not covered by our returns or warranty procedures.

## **SAFETY NOTICE**

Unless your filtration kit (filter, pump and any optional heating) is housed within a secure waterproof filtration enclosure, it should be placed at least 2 metres away from a swimming pool. You may need to purchase additional pipe and fittings if a filtration enclosure is not being used.

It is important to ensure the electricity supply for the filter pump or any other electrical equipment, has a 30 mA RCD protection circuit and conforms to current electrical regulations.

**NEVER LEAVE CHILDREN UNATTENDED AROUND THE POOL WHEN COMPLETED OR ANY STAGE OF THE CONSTRUCTION.**

The pool is designed for domestic use. Running along the top shelving, diving, or jumping in from the edge must not be allowed under any circumstances. The pool is not suitable for the addition of a diving board.

## Building a Concrete Base



The recommended minimum base for a wooden pool is a 150mm (6") thick concrete pad. We recommend using a steel reinforcing mesh as this will greatly increase its strength. Every site is different so you should give due consideration to increasing this specification if you have unstable ground or any other concerns. If in doubt seek the advice from a civil engineer.

Never construct your pool on made up ground, always dig down to undisturbed subsoil and remove all vegetation and sharp objects.



The minimum size of the concrete base required for your wooden pool is shown in the 'Laminated Wooden Pool Base Layout Drawings'. Use a selected datum point to carefully measure any positions of wooden pool bracing (if pool is supplied with bracing) and dimensions of the concrete base.



When you are satisfied with your brace positions lay them on a bed of mortar approximately 35mm thick. The brace should be supported as shown to support it while the cement cures. If you are using multiple braces along one wall of a wooden pool, make sure they are perfectly in line with each other. Use a spirit level to ensure the vertical part of the braces are "plumb" (upright level).



If you have a particularly large base to do you may consider doing it in sections, to allow for expansion within the concrete. In this picture, we are building a 5m x 10m wooden pool and have chosen to do it in three sections, by shuttering each section with wood. Lay the reinforcing mesh on the horizontal part of the braces. We have also used engineering bricks on the edge just to support the mesh. A good tip to prevent your concrete pour going off too quickly, is to lay some old polythene down and this will give you more time to finish the concrete to a nice smooth finish.



This picture shows section two of three before pouring concrete. Again, we have re-used the wooden shuttering. The main drains (optional) have been bedded on mortar to finish level with the top of the concrete base and left with their plastic seal covering them, this ensures that the concrete doesn't block the drains or fill any screw holes.



It is important that your concrete finish is smooth, as rough concrete can damage the liner. It needs to be flat and level, as any imperfections will show though. The pool liner and floor felt will not hide imperfections such as tamp lines or trowel marks. If you have any pipe work you wish to include, such as main drains, install them equally apart as shown to avoid entrapment and so they are level with the top of the concrete. Ensure you have the minimum pipework joints required below the concrete. For more detailed instructions on gluing joints look at the Installing Pipework and Equipment section.



This is our concrete base complete, it was poured in three sections. (Please note our image shows a wall around our base as this is a test site. It is not necessary to build a wall around the pool).

Make sure your concrete base has fully cured before proceeding to build your wooden pool.

## Total or Partial In-ground Installation

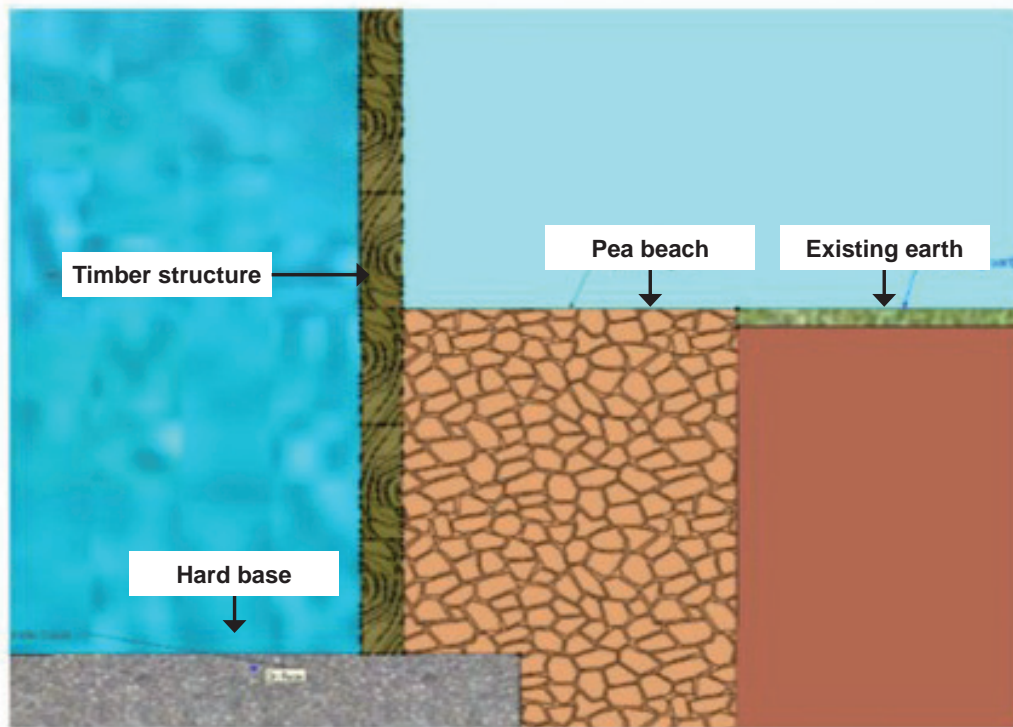

Plastica Wooden Pools can be installed above ground, partially in or fully in ground. However, if you do have the pool fully or partially in ground you will need to ensure that there is adequate drainage so that the timbers of your pool are not to be permanently submersed in water. Use an adequate amount of pea beach around the structure, if possible with a run off to a soak-away or similar, so that water cannot build up around the structure and rot the timbers. If an adequate amount of drainage in the form of pea shingle or similar has not been used, this may affect the warranty.

This product has been treated with ACQ which is child play friendly and is warrantied against rot and insect attack (10 years on 44mm wood and 5 years on 27mm wood). However, if this product is being installed completely or partially below ground level, you will need to install adequate drainage around the pool. We recommend 300mm - 450mm width of pea shingle, all the way around the product. Never use a plastic membrane around the outside of product as this will accelerate any deterioration of a timber product.

The timbers are treated for ground contact only and are not to be submersed permanently in water. Please also note that any modification to a wooden structure including drilling or cutting of a wall plank will void the warranty on the modified plank. As a precaution if you do require to modify a plank, we suggest that you treat the cut area with a good quality timber preservative if below ground level. Ensure any treatment does not come into contact with the liner.



# Building the Timber Structure

Please check the contents list and drawing to establish that all parts are present on delivery, you must report any damaged or missing items as soon as possible.

**Top Tip:** lay out the wooden wall planks in an orderly fashion in the centre of the pool to be built. This will save you from having to climb in and out of the pool too much and could save you time and money.

## Understand the Wooden Pool Wall Profiles



Note: the four different types of profile used for building the structure walls.

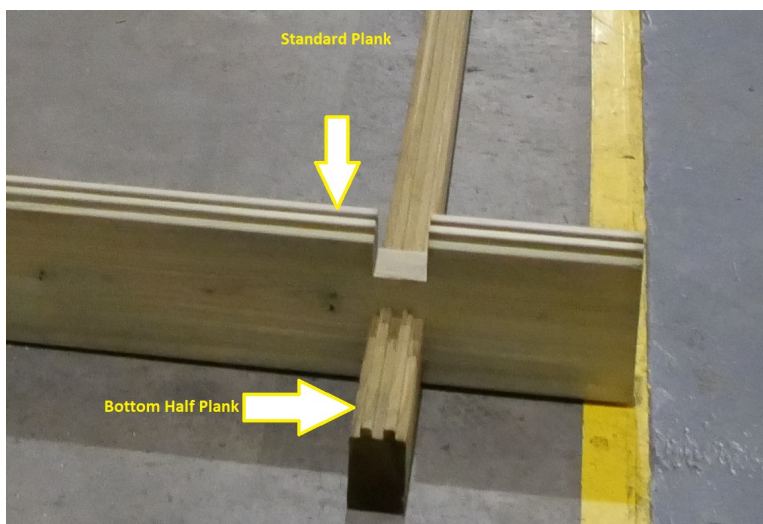

## 4m x 2m Nasca

First lay down the two Bottom Half Planks (Two tongues on top with a flat bottom). Then the Standard planks (Tongues on top and grooves on bottom)

## Building the Wall Structure 8m x 4m, 8m x 2m only



On the long walls of the wooden pool, the walls are joined and staggered using four stainless steel tie rods per wall. To start the tie rod, identify the bottom half planks with 30mm holes drilled on the underneath.



Fit a large washer and a Nyloc nut to the end of each tie rod. Insert the tie rod through the hole as shown, Once secure, this will enable you to clamp down the walls vertically later on.



Position your bottom half planks with the tie rods pointing upwards. Please wear safety glasses from this point of installation.



Knocking Block

## Building the Wall Structure

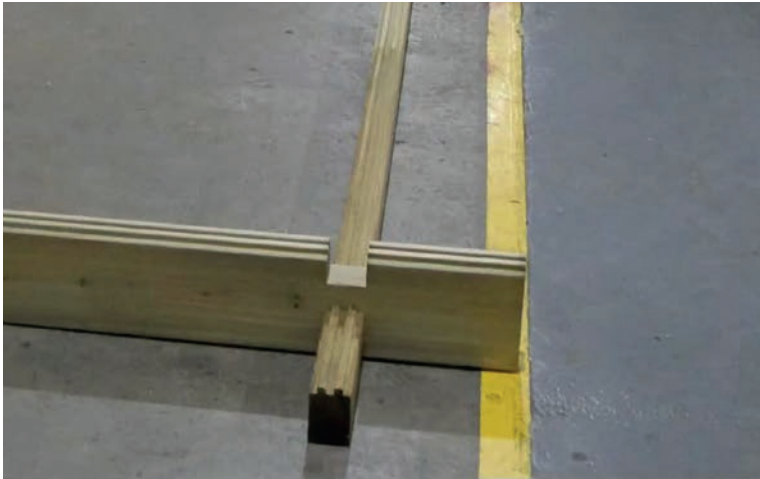

The next planks to use are standard planks, these have both tongues and grooves. Once you have laid two of these down and interlocked them with the first layer of bottom half planks, you will have created the outline of your wooden pool. Note: many people make the mistake of using the top full planks as the final planks to create to outline of the pool because they have a flat bottom. This is not the case as the standard plank you should be using has grooves on the bottom.



From this point onwards it is essential that you use the knocking blocks provided. Do not use a mallet directly on the pool timbers as you will flatten the tongues and may damage the timbers making it extremely difficult to install the pool walls.

When fitting the wall planks, make sure you place the plank down evenly over both notches and locate the tongue and groove between each plank, before you use the mallet to close the tongue and groove tightly together.

Image from different pool to show example



This image shows a plank evenly being interlocked. It should go downward with the plank remaining horizontal. When installing longer planks, get somebody to help you to do this. The best way to install longer planks is two people tapping the plank downward at each end and locating the plank properly before hitting it tightly together.

## Building the Wall Structure



### 8m x 4m, 8m x 2m only

For the long walls on the 8m x 4m, 8m x 2m pool carefully lower the planks over the stainless tie bars. Each layer of wall planks will be staggered and you will notice the joins line up directly on a wooden pool brace. You may need to tap the ends of the planks to close up any joins.



Once you have 2 full planks on the ends of the pool, you can install the low level suction plank (hole located offset) and inlet plank (hole located in the centre). We have installed the inlet and low level suction at opposite ends of the pool as this will increase water-flow. It is not usually necessary on small pools but on larger pools it helps gain better circulation of water. To do this, extra pipework would need to be purchased from your retailer. You can install these at the same end of the pool. However if you do, it would be better to install the inlet one plank above the low level suction on the 4th layer. The picture shows the cut out for either a low level suction or inlet, (note the flower pattern is on the inside of the pool).



### 8m x 4m, 8m x 2m only

Continue to build up the structure walls. Note: the staggered long walls have one long plank and one short plank for each layer. Each layer alternates with the joins resting against the metal braces.

## Building the Wall Structure



Continue to lay down the planks until you reach the 8th plank from the ground on the filtration wall and insert the vac point plank. This will need to be installed on the same wall as the low level suction.



This picture shows the cut out for either a low level suction or inlet, (note the flower pattern is on the inside of the pool).



Continue to lay planks until you reach the lower skimmer plank the recess must be in the inside of the pool, see image below.



### **WARNING!**

The skimmer must be placed into position before adding the upper skimmer plank, otherwise you will have to partly dismantle the pool to install the skimmer.

## Building the Wall Structure



Once you have placed your skimmer in position, continue to build the layers of the pool. The structure wall will finish with two half planks.



Level the skimmer and fix in place using the 40mm x 3.5mm screws provided in the Fixing Kit.



Note the four fixing positions, you may need to drill pilot holes before fixing the unit to the wall. Keep all the gaskets and screws safe until the liner is installed.

## Building the Wall Structure



Insert the wall fittings for the inlet, low level suction and vac point. Using the 3.5mm x 20mm screws provided in the fixing kit. Keep all gaskets and screws and face plates safe until the liner is installed.



### 8m x 4m, 8m x 2m only

When you have built the structure walls, you will need to tighten up the tie bars and cut off any excess tie rod. You can cut the tie rod using a hacksaw or a suitable cutting blade in an angle grinder.

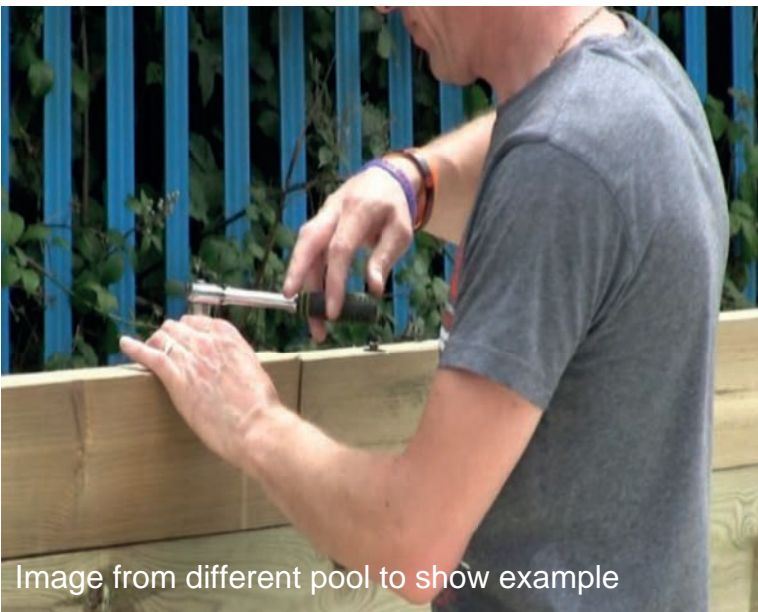

### 8m x 4m, 8m x 2m only

Firstly, trim the tie rod down to somewhere near to the level of the top half plank.

Next, add one of the large stainless washers and full nuts, tighten using a 17mm socket set.

## Building the Wall Structure



**8m x 4m, 8m x 2m only**

Trim any excess tie rod flush with the top of the pool wall with a hack saw or angle grinder.



**8m x 4m, 8m x 2m only**

It is important the tie rod finishes flush with the top of the pool wall as the top shelving board rests on the wall and you don't want the tie rod to foul the top shelving.

## Building the Wooden Step Ladder



To help with the ring-beam installation and to make it slightly easier, the external ladder needs to be assembled as follows:

Lay down one of the wooden step sides, insert all four treads into the slots machined out of the step side. It may need tapping gently in place with a rubber mallet.



## Building the Wooden Step Ladder



Insert the treads with care into the other side and press the steps together.

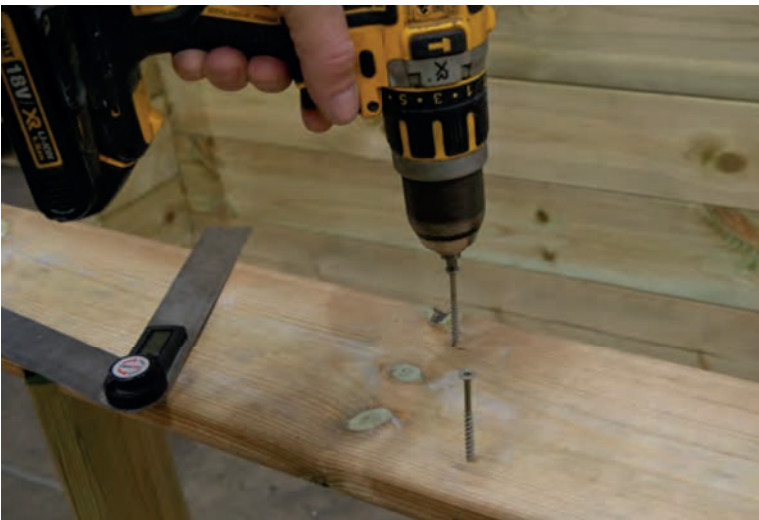

Carefully mark two holes on each of the treads and fix two coated screws 4.5mm x 65mm. Turn the unit over, ensuring everything is in place and repeat marking and fixing two screws to each side of the treads.



When you have finished assembling your wooden ladder put it aside until it is required to help with the installation of the ring-beam.

## Installing Wooden Top Ring-Beam and Support Blocks

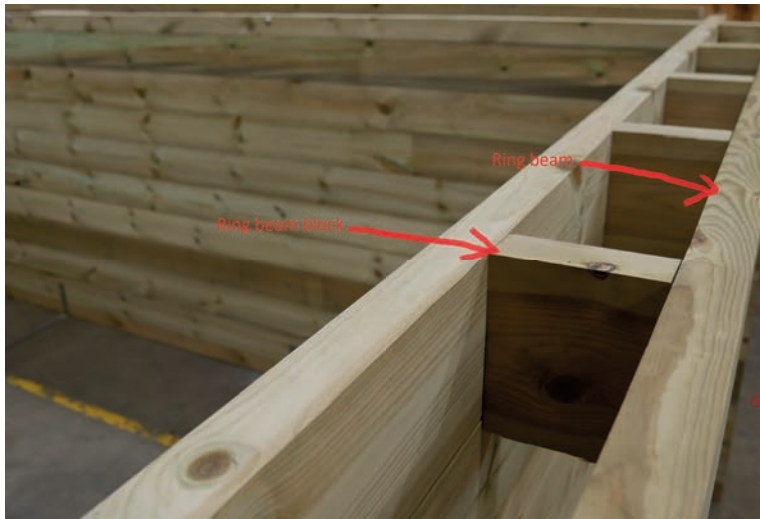

Examine the laminated drawing provided carefully. You will note there is a large timber (ring-beam) which runs around the perimeter of the pool at the top of the structure walls. This gives strength and support to the top of the pool, whilst also providing a fixing point for the top shelving. Take note on the provided A3 laminated drawing of the positions of the ring-beam and ring-beam blocks and carefully mark out locations. You will note that the ring-beam sections are pre-cut for the skimmer and ladder sections. **Please ensure the ring-beam timbers are not mixed up and are used in the correct positions.**



Fix the ring-beam blocks on your marked positions from the inside of the pool using the 5mm x 100mm screws.



On the inside of the pool use two 100mm gold screws to fix the ring-beam blocks.

# Installing Wooden Top Ring-Beam and Support Blocks

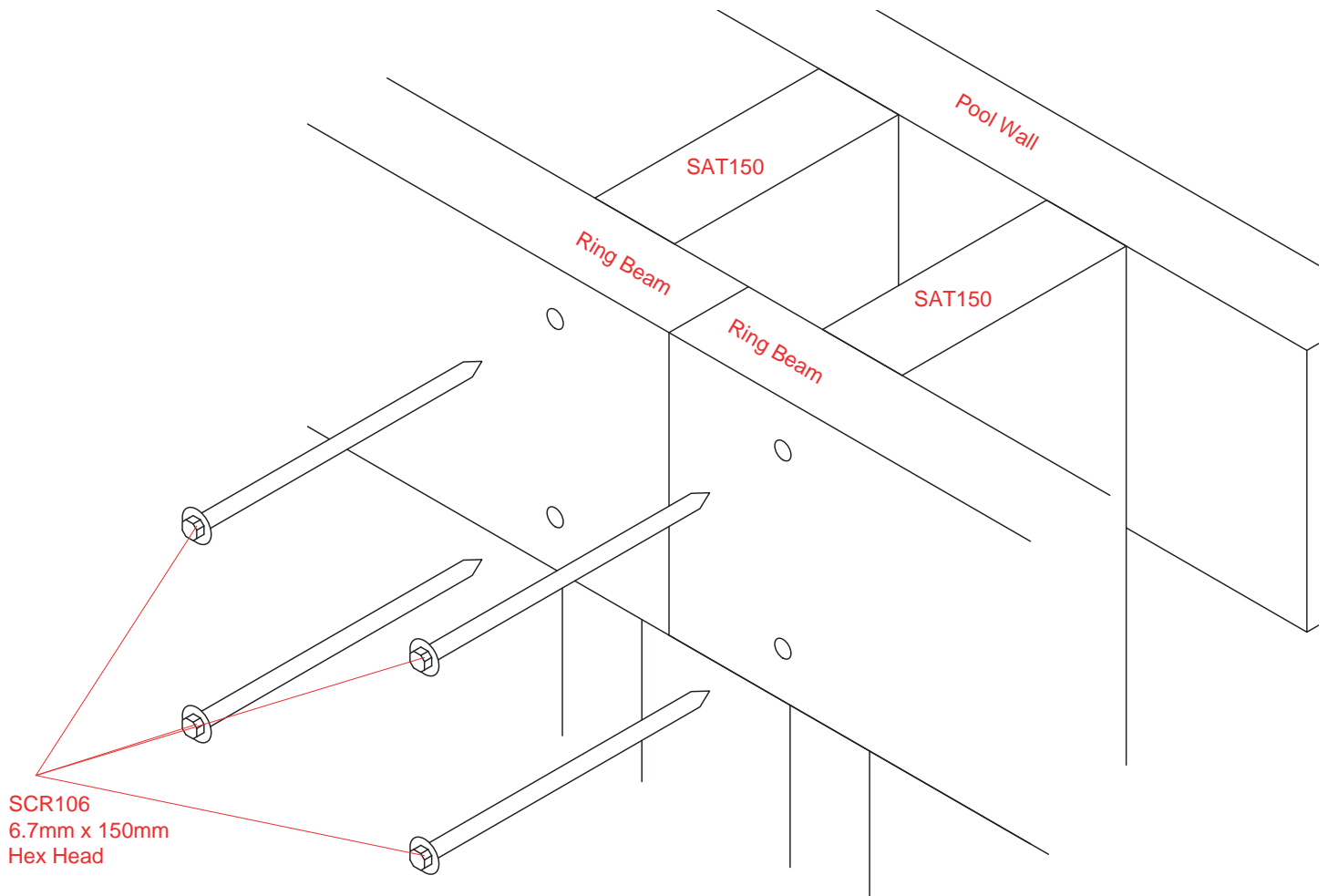

If you have a joined ring-beam these should be joined at the vertical support sections as per the diagram above. Tightly butt join them together and fix in place using the 150mm Hex-head screws.

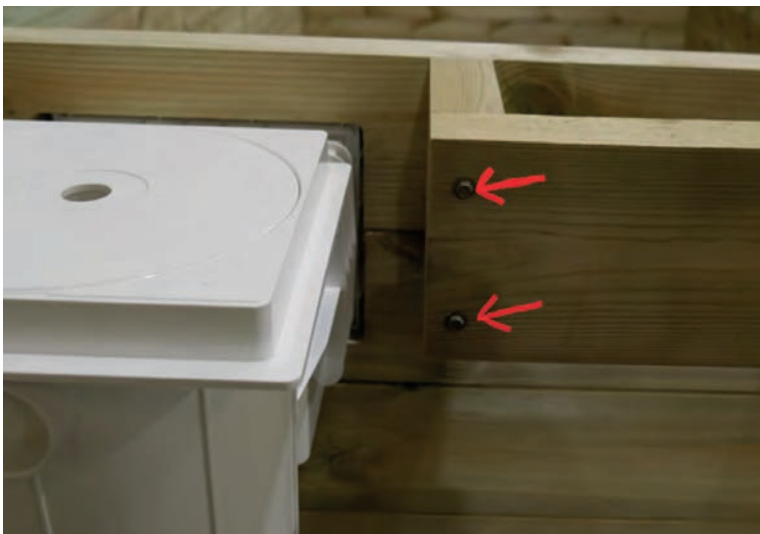

When installing ring-beam and the ring-beam blocks pay particular attention to the skimmer and ladder locations ensuring the correct parts and positions are used. Note: on the outside of the pool, either side of the skimmer or ladder positions, 6mm x 150mm Hex-head screws are used. Also, it may be necessary to trim either ring-beam or ring-beam block if it is too tight.

## Installing Wooden Top Ring-Beam and Support Blocks



At every cross section in the main timber walls the 150mm x 6mm Hex-head screws must be used to fix the main ring-beam in place. Use a small section of the end cap channel and place it on the end of the wall. This will help gauge the location of the ring-beam. It may be necessary to trim the ring-beam to fit.



Use the longer ladder ring-beam blocks in accordance with the drawings. Place your wooden steps against the wall ensuring it is seated properly against the floor and the wall. This helps set the spacing for the wooden steps.



This picture shows the installed ring-beam with ladder positioned.

## Installing Wooden Top Ring-Beam and Support Blocks



On the out side of the pool when fixing the ring-beam to the ring-beam-blocks the majority of fixings are the 5mm x 70mm stainless countersunk screws as pictured left. Use the screw digger supplied in the Fixing Kit to countersink the screw hole slightly, this makes it a much neater fixing.

## Installing the Vertical Supports



You will need to mark and cut the vertical supports and metal brace covers. Firstly, mark the full height of the vertical supports and cut to length based on the wall and ring-beam height.

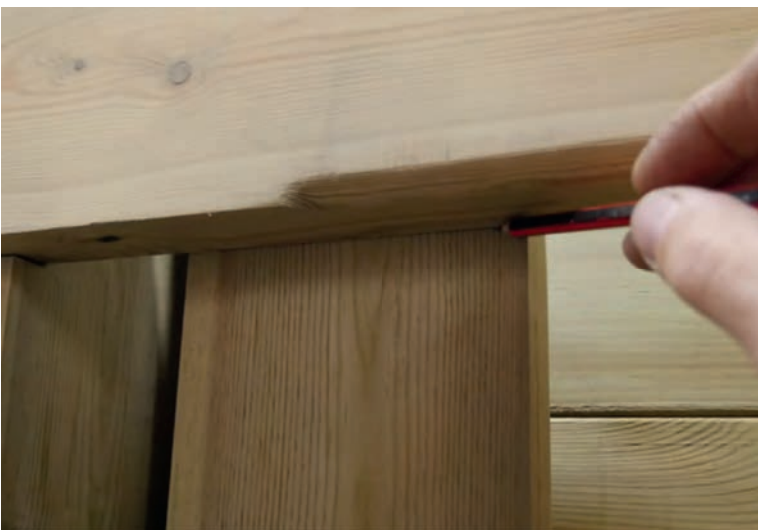

Next, individually mark each vertical support at the bottom of the ring-beam. Measure the distance from the outer wall to the inside of the ring-beam (it measures approximately 123mm).

## Installing the Vertical Supports



Cut out the required amount, so when the vertical support is snugly in place it is no higher than the pool wall and sits nicely under the ring-beam.

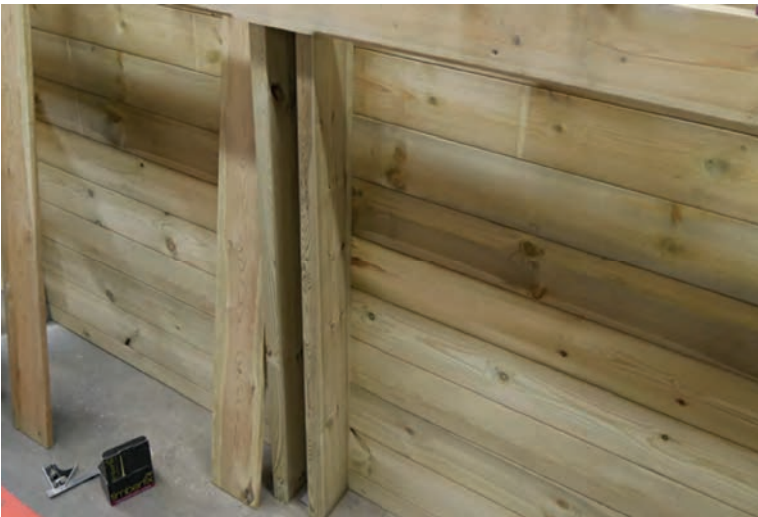

Vertical supports should look as in the photograph to the left when placed into position.

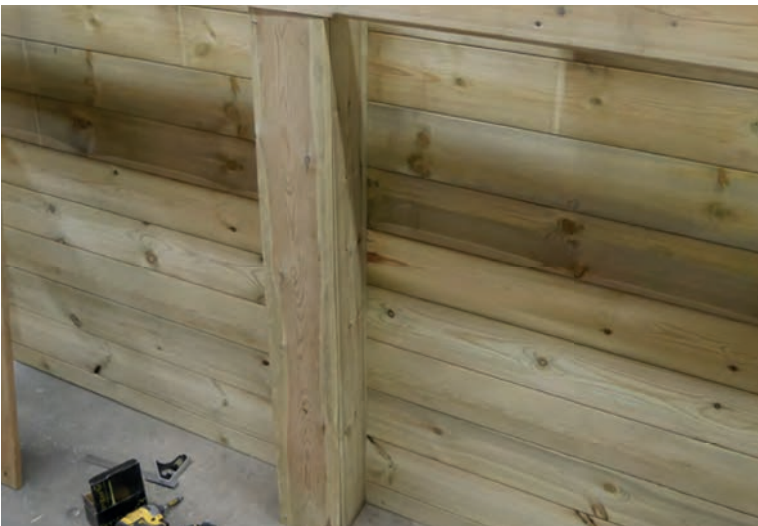

Measure and cut each metal brace cover to suit each set of vertical supports.

## Installing the Vertical Supports



Use the metal brace cover to ensure the correct spacing between the vertical supports, by using the width of the board as a guide.



On the inside of the pool using the 100mm screws provided in the Fixing Kit, fix a screw into the vertical supports through each wall plank as shown. It is best to use a spirit level and fix a screw at the top and bottom of the wall first, then fix a screw through each individual plank. It is handy to have another person on the outside to hold the vertical supports against the wall while you do this.



On the outside fit four 5mm x 70mm stainless screws supplied in the Fixing Kit through the ring-beam into the vertical support.

## Installing the Vertical Supports



Finally, fit the metal brace covers using ten 4.5mm x 65mm coated screws per brace cover, evenly spaced.

### **PLEASE NOTE**

**Further information in this booklet may be from generic instructions however, the principal is always the same.**



## Installing the End-capping Channel



Fit an end-capping to each end section of wall, you may need to gently tap it in place with a rubber mallet, then mark it with a pencil and cut to length.



Work your way around the pool trimming each end-capping to length.



Fix each end-capping in place using the 4.5mm x 65mm screws provided in the fixing kit.

Fix one into the top and bottom planks of each wall section, then two more spaced out evenly between the top and bottom screws.

In total there should be four screws per end-capping channel.

## Fixing the Top Shelving



The top shelving which surrounds the pool comes with four inner planks and four outer planks. When a section of top shelving joins another, stainless steel biscuits are slotted into a machined groove at the end of each plank, these should be used at every join.

Take your time to evenly space out the top shelving and manoeuvre it into the correct position. This is usually one of the trickiest parts of the build, so it is very worthwhile taking your time and going around the pool, double checking everything before you start fixing it down.



It is best to start with the outer shelving, measuring the back edge of the top shelving to the end-capping channel, so you can ensure you have an even overhang all the way around the pool.



Locate the top shelving packed with the label, this is the skimmer hatch, please ensure you do not lose any of the components, this particular plank is an outer shelving.

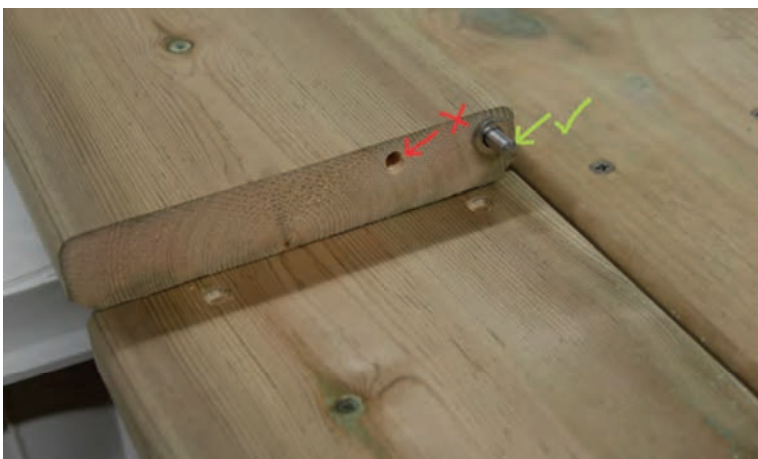

Make sure you use the hole at the edge of the timber, this will be the pivot point for the skimmer hatch, you should also have two washers per pin.

## Fixing the Top Shelving

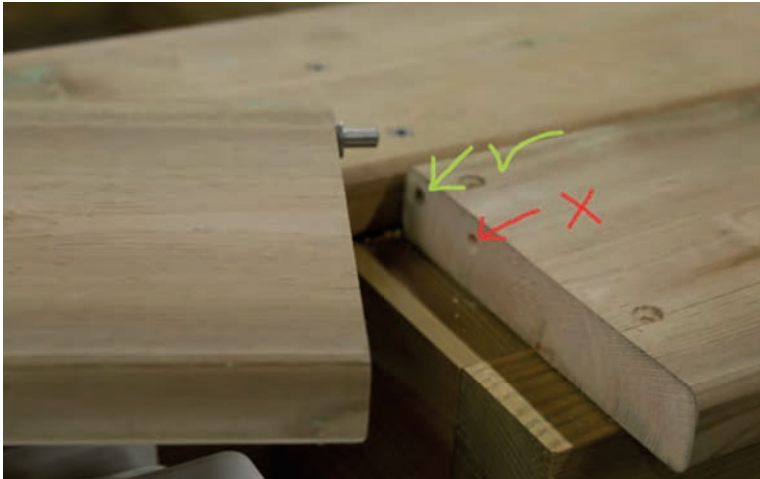

Connect the outer top shelving to form the skimmer access hatch.



Use a straight edge to line up the outer edge of the top shelving with the skimmer hatch to keep it in a straight line. You must make sure that when you mark out screw positions the screws will not come into contact with the liner or liner-lock. Any warranty for a mechanically damaged liner will not be covered.



When you have connected the inner top shelving using the stainless steel biscuits, take your time to align top shelving evenly to create a gap between the inner and outer top shelving, of a similar size.



Use the 4.5mm x 65mm coated screws to fix down the top shelving. There should be two screws fixed per board at every support point i.e. ring-beam blocks, vertical supports and wall sections. Top tips: use the screw digger bits supplied with the Fixing Kit to pre-drill to a shallow depth and slightly counter sink for a nice clean finish. Also, you can use timber wedges or a clamp to open or close gaps in the top shelving if a board has a bend in it.

## Installing the Liner-lock



Liner-lock is a plastic extrusion that is used to secure the pool liner. This needs to be fitted to the inside of the pool around the entire perimeter. When cutting the liner-lock cut it at either 45 degrees to fit the corners of the pool or 90 degrees. Other than aesthetics it makes no difference, as when the liner and liner-lock wedge is installed you cannot see the liner-lock. You can use a chop saw, panel saw or hack saw to do this. It is important that where the liner-lock joins you make sure it is lined up properly at the groove to accept the liner running continuously, without any misalignment. As you can see in this photo the join runs with the groove completely in line.

Pre-drill the liner-lock every 300mm with a 3mm drill bit, as this will ensure inserting the screws is much easier and prevent any injury from slipping with the drill when you are starting the screw.

Use the 3.5mm x 40mm screws provided to fix the liner-lock all the way around the pool.

## Fitting Inlets/Low-level Suction or Vacuum Point



When installing an Inlet or Low-Level suction (number of Inlets/Low level Suctions and Vac - point dependant on model) you will notice a flower shaped recess on the inside of the pool where these fittings are located.



Insert the back part of the fitting and screw it to the wall using the 3.5mm x 20mm screws provided as shown. Keep the other parts and gaskets somewhere safe for later. Make sure you have screw holes in the 12 and 6 o'clock positions.



At this stage, you can carefully stick one gasket on to the face of the fitting as shown, ensuring you line up the holes correctly when applying the gasket. Insert one screw, top and bottom (do not fully tighten) with the cross in the screws facing North, East, South and West (N,E,S,W). This makes it easier when having to find the screw heads underneath the liner. The same instruction applies to all pool fittings in the walls, round fittings are done like this and rectangular fittings such as skimmers would have a screw in each corner.

## Laying the Felt Underlay

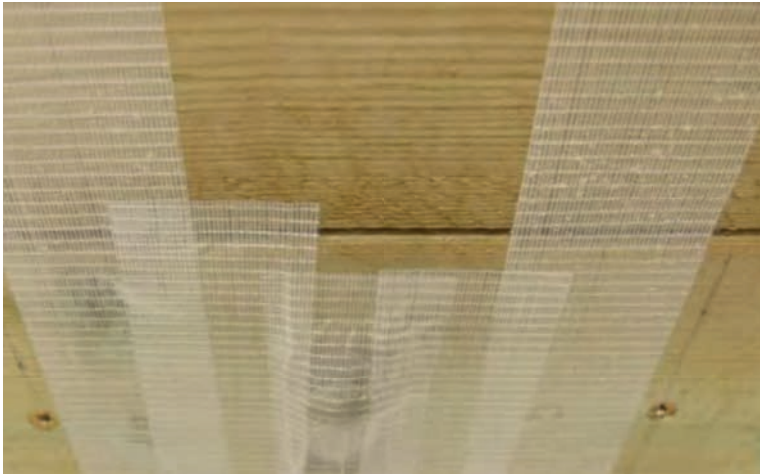

If there are any protruding fixings or sharp splinters inside the pool at this point, use a piece of underlay tape to cover them up. Do not use any other tape other than the underlay tape supplied.



Ensure the pool floor is completely clean from any debris or other objects. Anything left in the pool can be unsightly for years to come and could damage the liner. Lay the felt underlay out completely covering the pool floor and an overlap up the wall of about 10-20mm.



Avoid joining edges together which have been cut on site. Always try and tape two machined edges together. Only use the tape provided, never use any other type of tape. Use a pair of sharp scissors to cut the felt, never use a knife. Make sure the felt does not overlap as this will show through the liner.



Finally, trim the perimeter of the pool by using the back edge of the scissors to score the felt between the pool floor and wall. This leaves a line in the felt that you can cut neatly along with a sharp pair of scissors.

## Foam Wall Protection



Locate the foam and spray adhesive. Start in one corner of the pool. Spray the adhesive on about 2-3 metres of wall section. Start unrolling the foam from that corner of the pool, pressing it firmly against the area of wall that you have just sprayed and work your way around the pool repeatedly. You can seal a join in the foam by using the underlay tape provided.



Pay particular attention to pressing the foam firmly into the corners and under the liner-lock of the pool. Avoid getting adhesive on any fittings such as the inlets or skimmer. Trim around the perimeter of the pool by running a sharp pair of scissors directly under the Liner-lock. Cut the foam away neatly around any pool fittings.



Finally seal any joins with the underlay tape provided.

## Installing the Liner



It is essential that shoes are removed for the next stage. Ensure you have read the Recommendations for Storage section at the front of this booklet and have kept your liner in a warm environment. If you haven't, we strongly recommend you do so, for a good period until the liner feels relatively warm and supple. A cold liner is much harder to install and you may not be able to remove creases in the liner. Before installing, make sure any fittings such as inlets skimmers and lights have gaskets in place and screws in the N, E, S, W positions as explained previously.



Unfold the liner and lay it to suit the shape of the floor. At one position on the wall of the liner, there is a welded seam. Ensure this doesn't run through with a skimmer. If it does, rotate the liner. Once unfolded, line up the floor corners of the liner with the floor corners of the pool structure.

Image from different pool to show example



Note: the pool liner will have been made smaller than the structure and the weight of the water stretches it into position.

Image from different pool to show example



Starting at a corner take one of the walls and feed it into the liner-lock. When you release it, the weight of the liner holds it in position.

Image from different pool to show example



## Installing the Liner



Carefully work your way around the pool, paying attention to the corners to make sure they line up correctly.



Use your feet to gently push the corners of the pool liner into place.



If the liner is not quite lined up, you can unhook it and straighten it so that it is all lined up perfectly.

## Installing the Liner

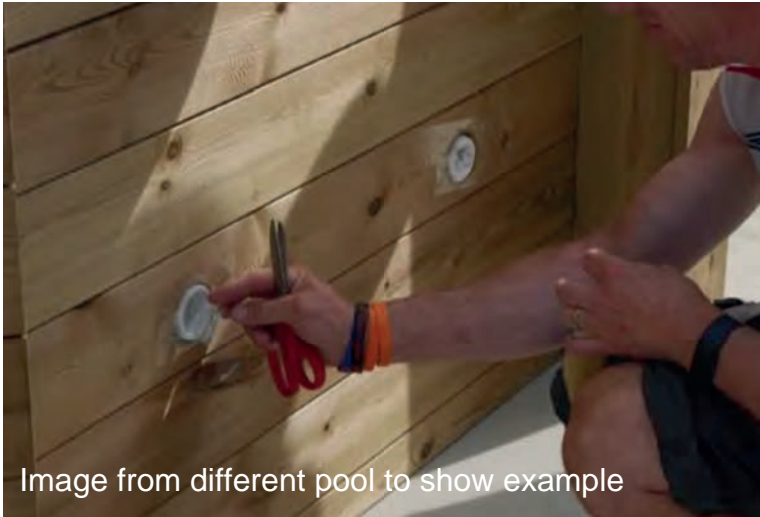

Image from different pool to show example

On larger pools use underlay tape to completely seal the fittings on the pool such as skimmers, inlets and lights. The idea is to make the pool structure as air tight as possible.

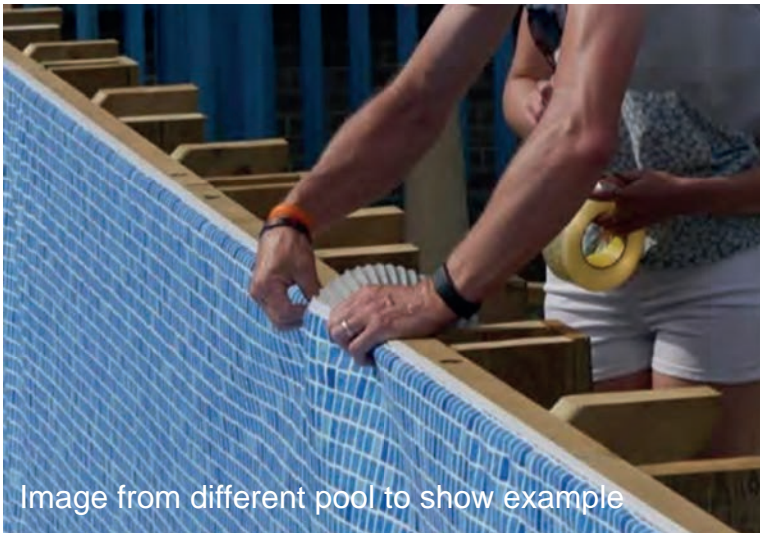

Image from different pool to show example

Using a vacuum cleaner with just the hose attached, peel back a small section of liner, and insert the hose as far down to the pool floor as possible. Make sure nothing can get stuck behind the liner. Attach as much liner back as possible into position around the hose. Then use the underlay tape to seal around the hose. You can now turn on the vacuum to help you.



Image from different pool to show example

Start removing any creases by systematically pushing them away from the centre of the pool floor towards the walls.

If you have any main drains (optional) be very careful not to tread on them.

Continue adjusting the liner and removing as many creases as possible.

## Installing the Liner

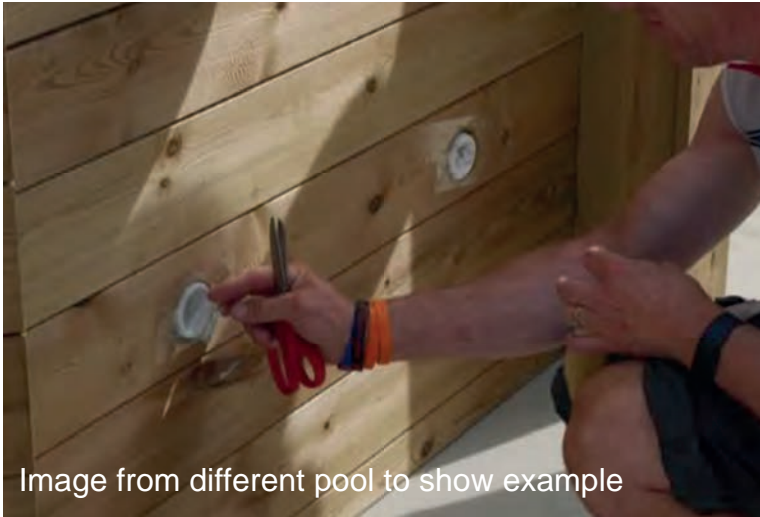

Image from different pool to show example

When you are happy with the position of the liner you can install the liner-lock wedge. The wedge goes above the liner into the liner-lock channel. This locks the liner in place. Start in a corner working your way around the pool pressing it firmly into place. When you reach a corner, measure it precisely and cut the liner-lock wedge to length. Alternatively, you can cut a simple 'V' shape out of the back of the liner-lock wedge. Get somebody to cut it standing away from the liner to prevent any accidents or damage to the liner. Carry on working your way around the pool cutting the liner-lock wedge to length as required.

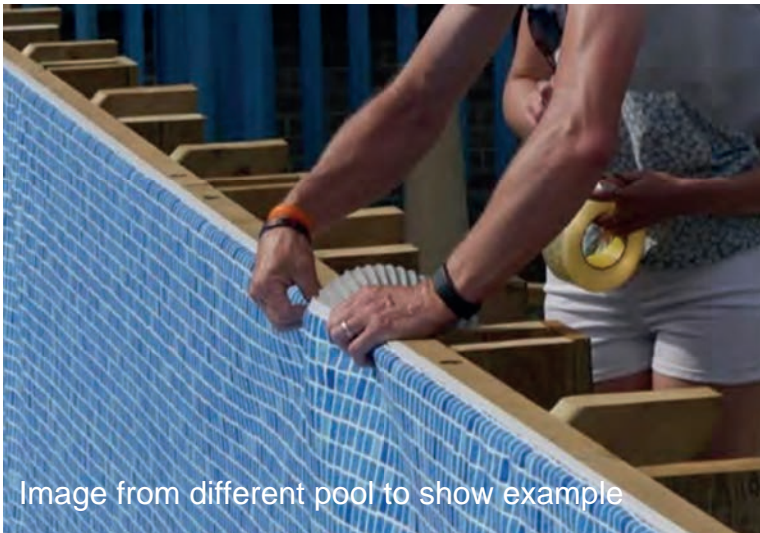

Image from different pool to show example

You can now start filling the pool with water. Continue to push any creases out of the floor by sliding your foot from the middle of the floor towards the pool walls.

Any stubborn minor creases that are left may be packing creases and should come out when the pool is filled and the water heated.

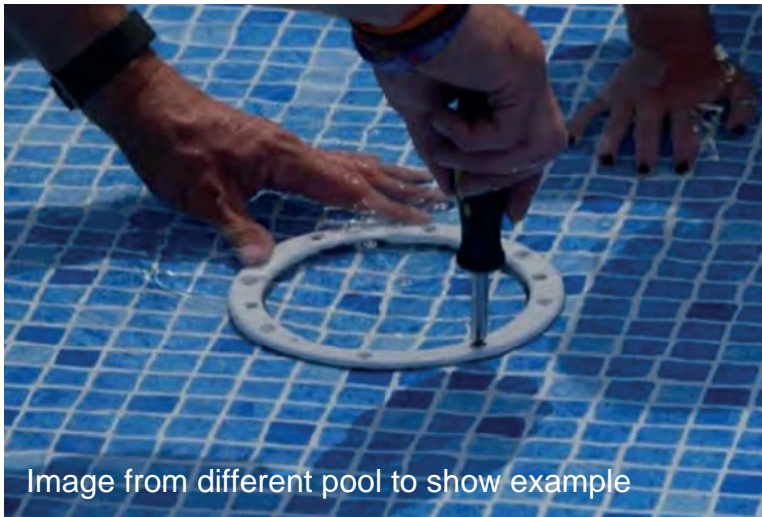

Image from different pool to show example

If you have main drains installed (optional) turn the water off after filling the pool with approximately 25mm of water.

Take extreme care whilst using a Stanley knife in a pool. Have somebody outside the pool who can hand you tools. Carefully feel for the head of the two screws under the liner. Remember you should have left the cross of the screw in the North, East, South and West positions. Make a tiny cut in the "cross" of the screw head. Then gently tease the screw head through the small incision you have made.

## Installing the Liner



You should have exposed the screw head, now carefully expose the other screw on the opposite side to the one you have just done. Once you have exposed both screw heads you need the face plate for the drain. Carefully apply the gasket to the face plate.

Remove one of the screws you have exposed (using a hand-held screwdriver) and insert the screw through the face plate back into the hole and start to tighten screw. Then swing the face plate to the correct position and remove and insert the second screw.

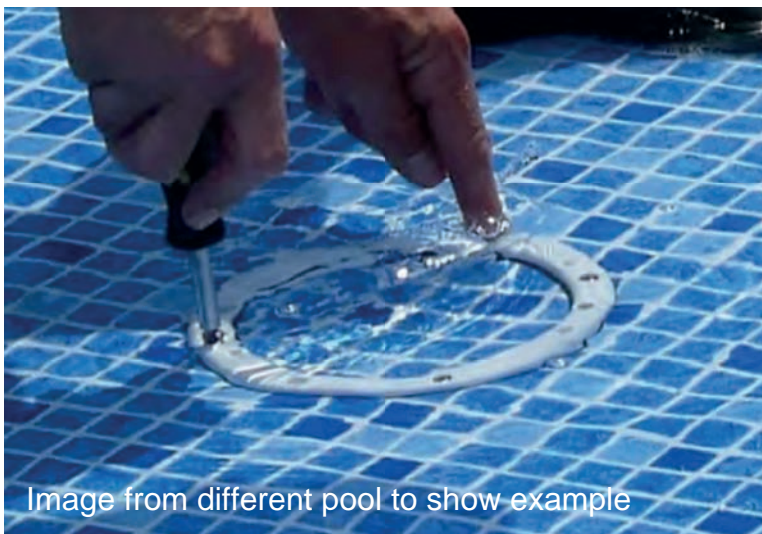

You can now fit the rest of the screws as the face plate gives the position of the remaining screws.

With a large circle gasket always insert one screw and then insert the screw on the opposite side, working your way around the gasket until all screws are tightened evenly.

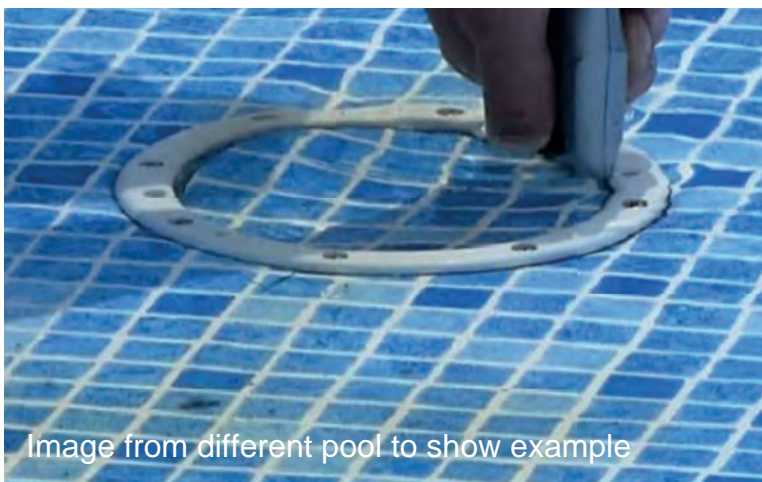

Assuming the pipe work for the main drains has had a ball-valve connected and the main drain face plate secured, you can carefully remove the liner material within the gasket with a sharp knife.

## Installing the Liner



Repeat the whole process for the second main drain.

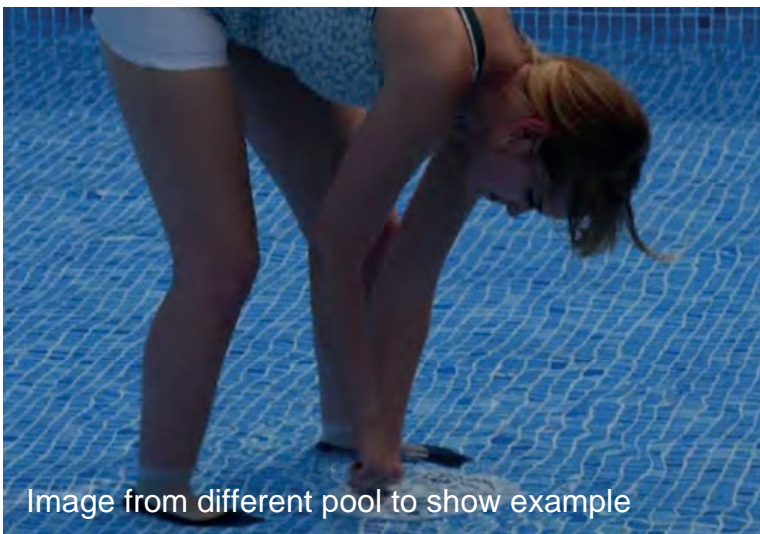

Now you can screw the main drain cover plate into place.



Before the water level reaches 50mm below the low-level suction/inlets you need to make the pool watertight. Start by using the PTFE tape provided. Use plenty of tape on the socket nipples to create a good watertight seal.

## Installing the Liner



Screw the socket nipple into the back of the Low-level Suction/ Inlets.



Ensure when you glue pipe work that you use the pipe cleaner supplied just before applying glue to both the fitting and pipe.

It is sometimes a good idea to dry fit pipe work before gluing. This way you can be sure your layout is to your satisfaction before gluing.

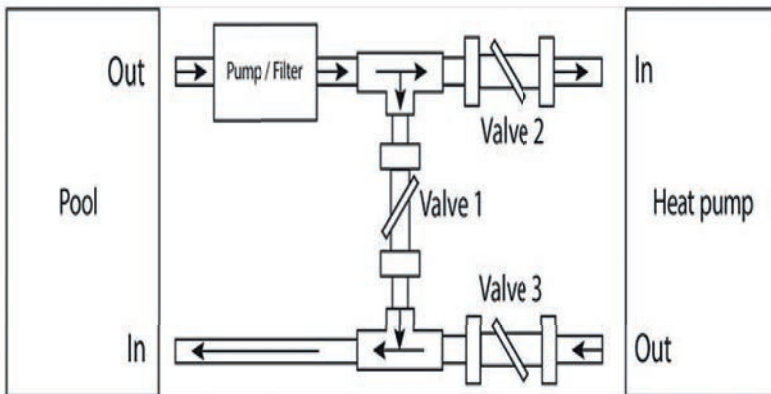

Before cutting in the fittings on the liner, plumb up any filtration equipment or counter current pipework to be installed. There is no specific diagram saying where each individual pipe fitting goes. However, as the diagram to the left shows, the principal is installing draining fittings from the pool such as skimmers, drains, low level suction or vac points. All of these should be on the “out” side of the pool going to the pump and filter. Any heat source should be plumbed in after a pump/filter before the returning to the pool. This system shows a bypass system with the use of valves so the heat source can be isolated or serviced.

Also, please be aware if you have a counter current/swim-jet system this would be an entirely separate pipework system.

# Installing the Pipework and Equipment

To keep your swimming pool clear and hygienic you need to use a filtration system alongside chemicals, refer to the Wooden Pool Operating and Maintenance Manual.

The simplistic view is water needs to go to the pump first via skimmer/s, low-level suction or main drains. It is then pushed through the filter which can contain either sand or glass media where the dirt is trapped. It can then return to the pool through the inlet fittings via a heater or heat pump (optional).

The valves and pipe work should be arranged so that it is impossible to have all the flow through the low-level suction. The high flow rate through one fitting could create an entrapment hazard which must be avoided.



Image from different pool to show example

Unpack the filter pump and position it before filling it with sand, it will be much easier to move whilst empty. Any electrical item must be at least 2 metres away from the pool unless enclosed by a filtration enclosure. We recommend enclosing the plant equipment for longevity.

The model of filter pump may vary depending on product purchased. Always read the manufacturer's instructions on how to assemble the product. Fill the filter with sand according to the instructions.

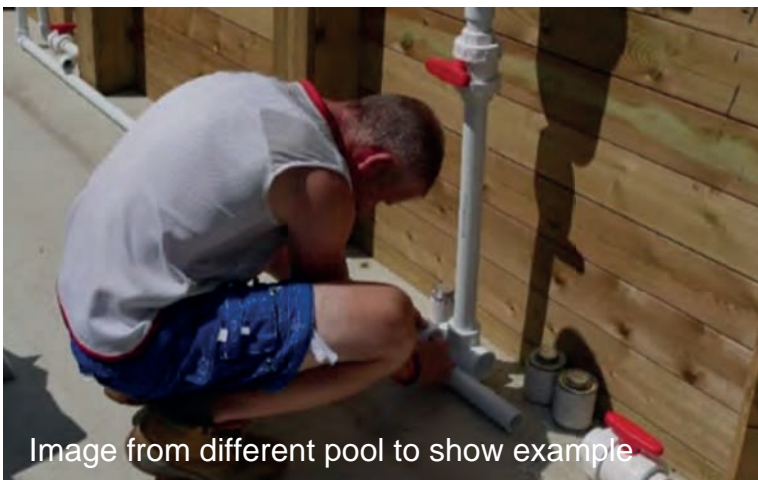

Image from different pool to show example

If you have an optional heater, assemble it after the filter pump according to the manufacturer's instructions.

The pipe work kit which is supplied is generous and there can be variations in fitting. It will only include fittings for filtration if a heater or other piece of equipment is purchased, additional pipework will need to be purchased.

Run your pipe work as neatly as possible. Where possible, install all pipe and fittings so they are resting on the ground. Trial fit all pipe and fittings without cleaner or glue, this "dry fitting" will save time in the long run and allow you to check work before committing to gluing.

Cut all pipework at 90 degrees and remove any burrs. Trial fit the pipe(s) and fitting(s) "dry fit".



Image from different pool to show example

Use pipe cleaner on both pipe and fittings, this removes any dirt or grease on the fittings and helps with adhesion of the glue. Give both the pipe and fitting a good coverage of glue and push together until set. On warm days, you may have to work fast as the glue can set quickly.

## Installing Low Level Suctions / Inlets



Next you need to cut in the low-level suction/ inlet fittings. It's useful to have somebody outside the pool to hand you tools.

The pool needs to be filled to approximately 50mm below the fittings.

Feel for the screw heads with your fingers. Very carefully make an incision into the 'cross' of the screw head, remember the cross of the screw head is in the N, E, S, W position. Once you have made the incisions, gently push the screw heads through the liner, ensuring the holes are as small as possible.

One gasket is on the fitting behind the liner, you now need to stick a gasket on the face plate ensuring the holes line up. Once you have done this, remove the top screw that is exposed. Insert the screw through the face plate back into the small hole you have made in the liner.

Now remove the bottom screw and let the face plate swing into position. You can now insert the second screw through the face plate and second screw hole you have made.

Always use a hand-held screwdriver.

Gently tighten the screws and fit the other two screws.

Cut out the liner material within the face plate.

Finally, screw in the eyeball/fixed grate or vac-point fitting.



## Installing the Skimmer(s)



Installing the skimmer is the same method as all the other pool fittings, you should already have one gasket fitted to the skimmer behind the liner and the screws are in the four corners of the skimmer. When the water level is just below the skimmer carefully insert a small cut in the 'cross' of the screw heads, and gently push the screw head through the liner.

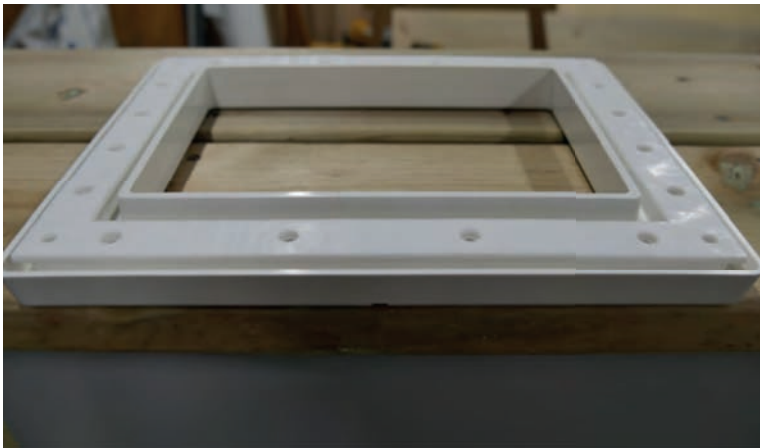

Apply the gasket carefully to the skimmer faceplate ensuring the holes line up.



Undo a top corner screw and insert it through the faceplate and back through the small hole you created. Swing the skimmer up and do the same for the other top corner.

You can now undo the bottom two screws and screw them back through the face plate into the small holes you made. Gently tighten the four screws.

Now insert the rest of the screws. Try and do it systematically, working from the middle of the skimmer top to the bottom. Work your way to the outer edges ensuring all the screws are tightened.



Insert the faceplate cover.

## Installing the Skimmer(s)



Carefully cut the liner from the inside of the skimmer with a sharp knife.

## Installing the Stainless Steel Ladder



Assemble the stainless steel ladder according to the instructions supplied with the ladder.



Attach the pots which come with the ladder. Line up the stainless steel ladder in line with the inside of the wooden ladder so as to give yourself enough room for fixing the bolts under the top shelving.

## Installing the Stainless Steel Ladder



Carefully mark around the stainless steel pots with a pencil, ensure your ladder is in the correct position. It should have the feet of the ladder resting against the inside of the pool wall and remain vertical and straight before marking the hole positions.



With the hole saw provided with the ladder, drill out the holes you've marked for the ladder pots.



Insert the ladder in the pots and ensure it fits its final position, mark the holes for the bolts.



Drill the bolt holes for the ladders pots with an 8mm drill bit.

## Installing the Stainless Steel Ladder



Insert bolts using the washers and nuts provided and tighten in place. This completes the ladder which is now a removable ladder.

The pool is now complete.

## Tool List

- Tape Measure
- Spirit Level
- Various Digging And Concreting Tools
- Socket set
- Heavy mallets
- Cordless drill driver
- Selection of driver bits
- 3mm, 4mm and 5mm drill bits
- Hand saw or chop saw (if available)
- Set Square
- Pencil
- Sharp scissors
- Hand-held screwdriver
- Sharp knife
- Hammer
- Sharp chisel
- Sand paper
- 85mm hole cutter (light installation only)
- Wet and dry vacuum cleaner
- Goggles/glasses and protective gloves



# Wooden Pool Warranty

*Plastica give a 10 year parts only warranty to the timber structure against wood rot and insect infestation*

Timber Structure .....	10 years
Liner .....	5 years
Top Shelving .....	1 year
Pump .....	1 year
Filter .....	1 year

**Terms of Warranty on Wooden Pool Structure:**

*The warranty duration on the wooden pool structure is 10 years on a pro-rata basis, reducing by 10% per annum.*

*eg. after 3 years the warranty covers 70% of any valid claim.*

*The warranty covers the 44mm timber structure from insect attack and rotting. This applies to the damaged wall planks only, providing they are returned to our St Leonards factory at the consumers cost and risk. Any replacements will be arranged in accordance with the above warranty with free of charge delivery back to site (UK mainland only).*

**Terms of Warranty:**

- 1. We will need to see the original proof of purchase.*
- 2. The pool must be installed in accordance with the installation instructions and remain in its original installation location.*
- 3. Wood is a natural product and movement and discolouration can be expected. Plastica Ltd accept no liability for any such issues that may arise.*
- 4. This warranty is between Plastica Ltd and the original purchaser and is not transferable.*
- 5. Plastica Ltd accepts no liability for any consequential loss.*

**Structure Warranty**

0 to 12 months	100%
13 to 24 months	90%
25 to 36 months	80%
37 to 48 months	70%
49 to 60 months	60%
61 to 72 months	50%
73 to 84 months	40%
85 to 96 months	30%
97 to 108 months	20%
109 to 120 months	10%

**Liner Warranty**

0 to 12 months	100%
13 to 24 months	80%
25 to 36 months	60%
37 to 48 months	40%
49 to 60 months	20%

# NAZCA 4m x 2m Plan

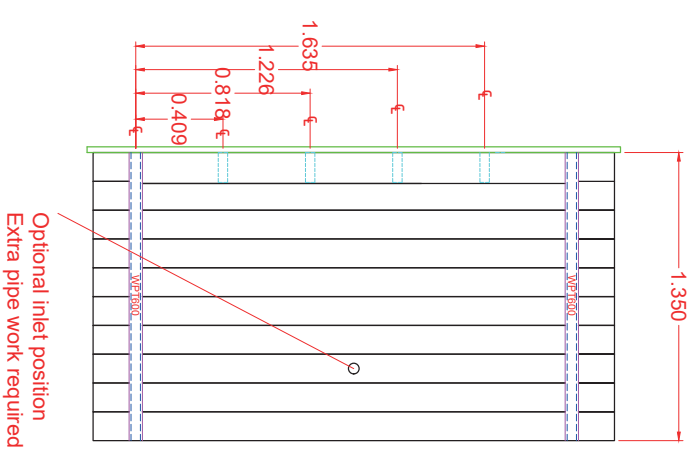
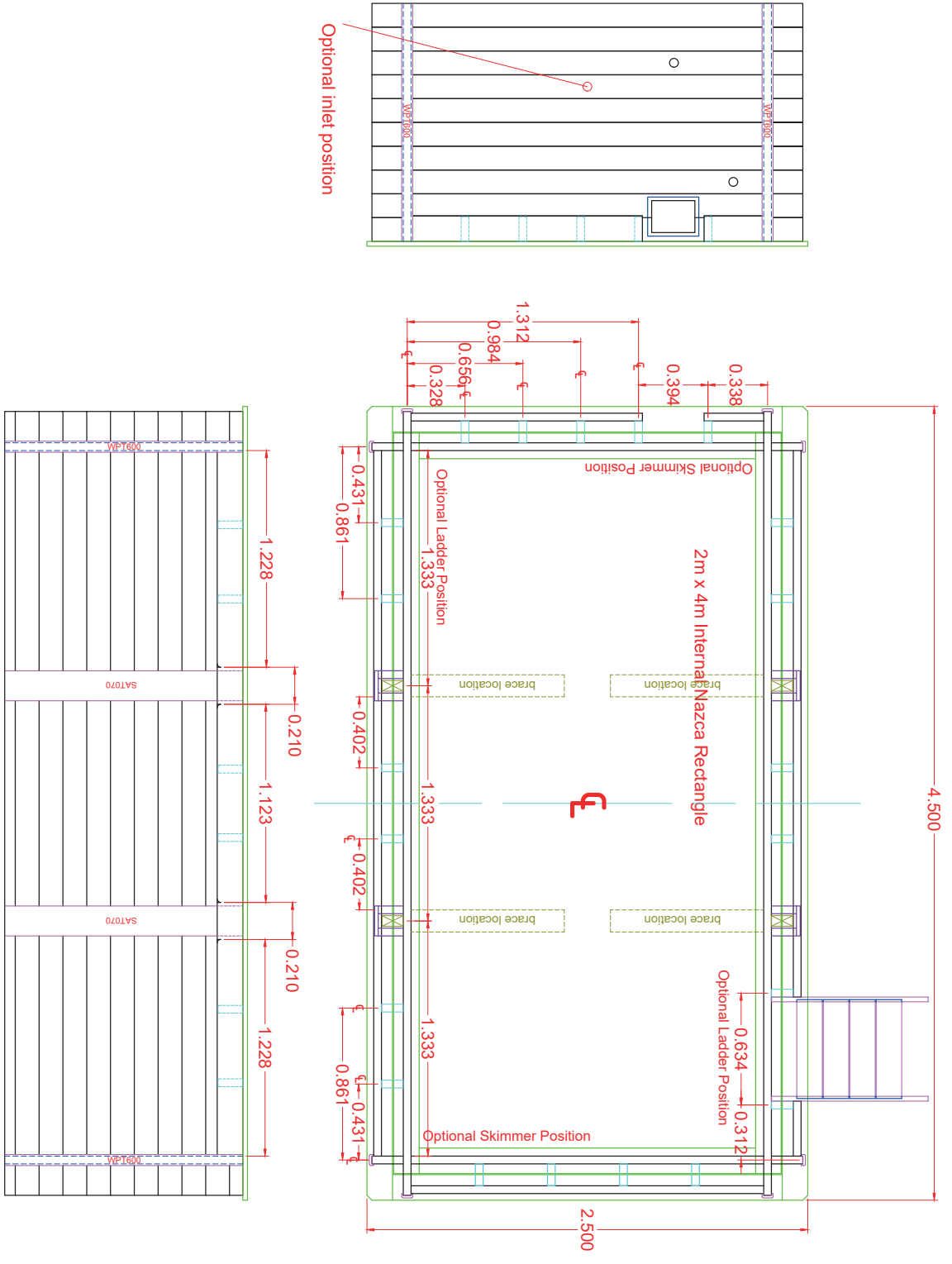

Wooden pool structure shown with 0.150m thick concrete pad given 0.3m clearance from pool wall. Guide only

# NAZCA 4m x 2m Brace position plan

BASE LAYOUT DETAILS FOR STRAP SYSTEM 4M X 2M NAZCA  
 ISSUE 1 - JK 21/06/2021  
 PLEASE REFER TO MAIN INSTRUCTIONS FOR STRUCTURE ASSEMBLY

CONCRETE BASE 4.688M X 2.688M

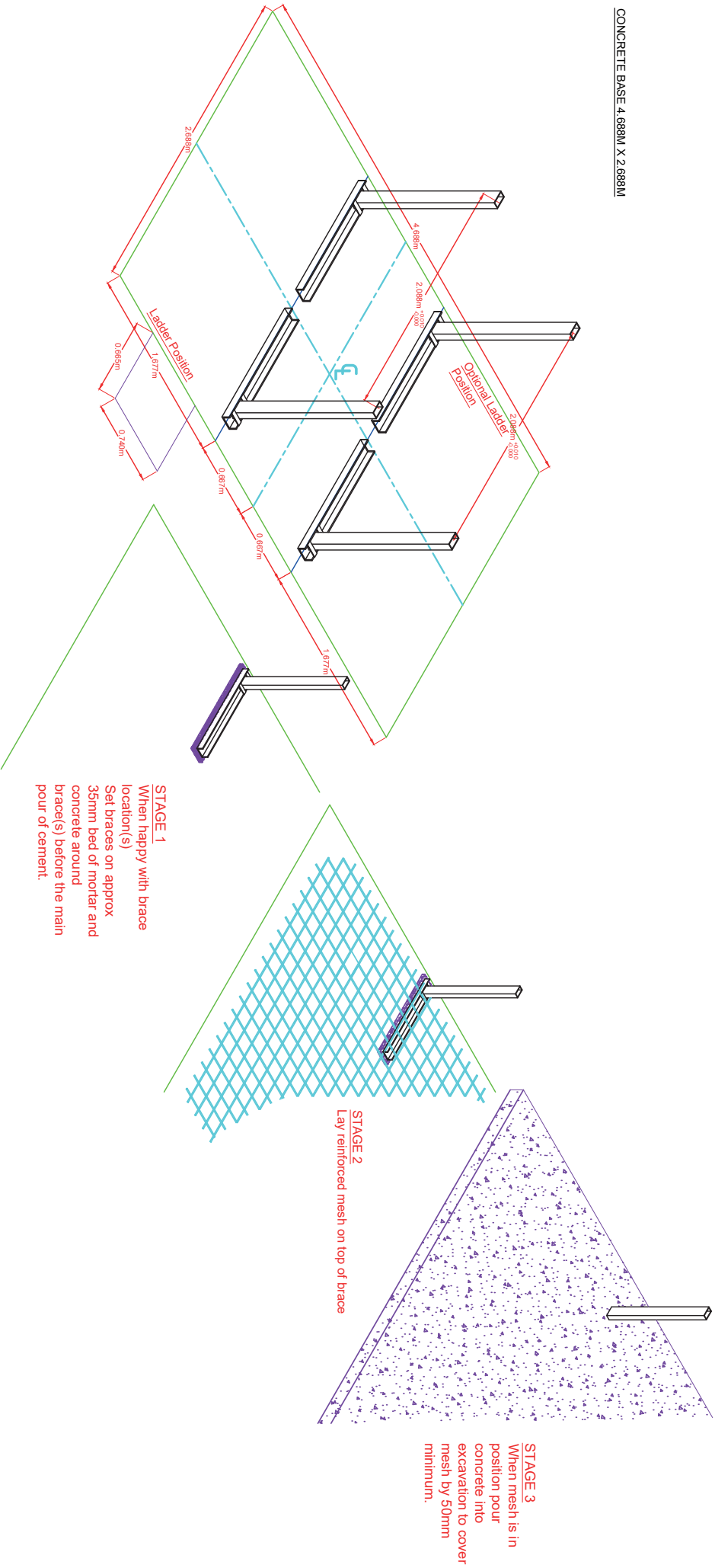

# NAZCA 8m x 4m Plan

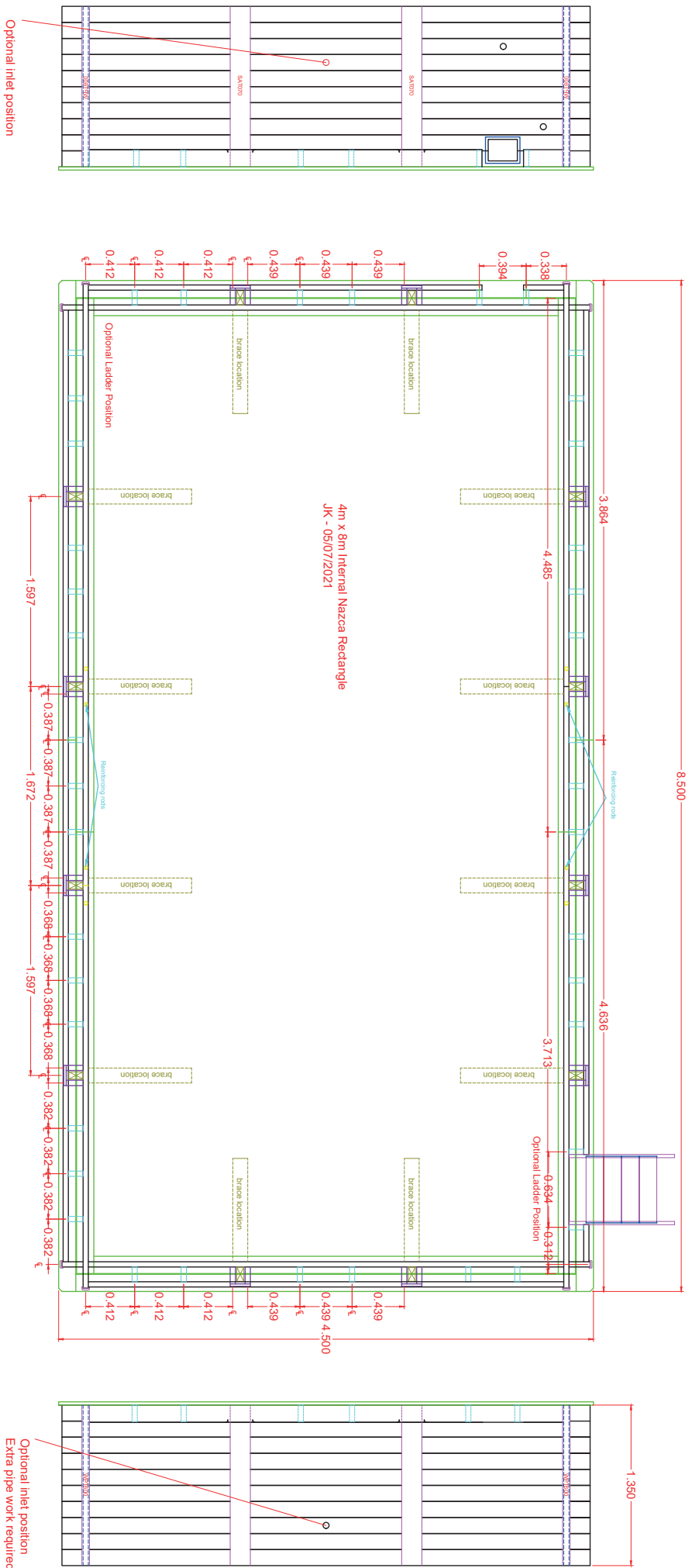



# NAZCA 8m x 4m Brace position plan

BASE LAYOUT DETAILS FOR 8m x 4m Nazca WOODEN POOL  
 ISSUE 1 - JK 22/06/2021  
 PLEASE REFER TO MAIN INSTRUCTIONS FOR STRUCTURE ASSEMBLY

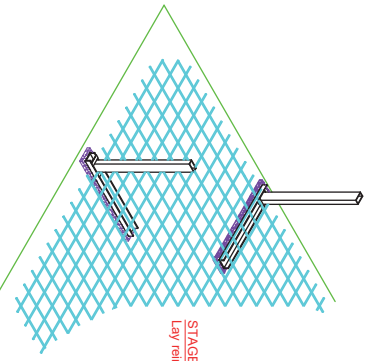
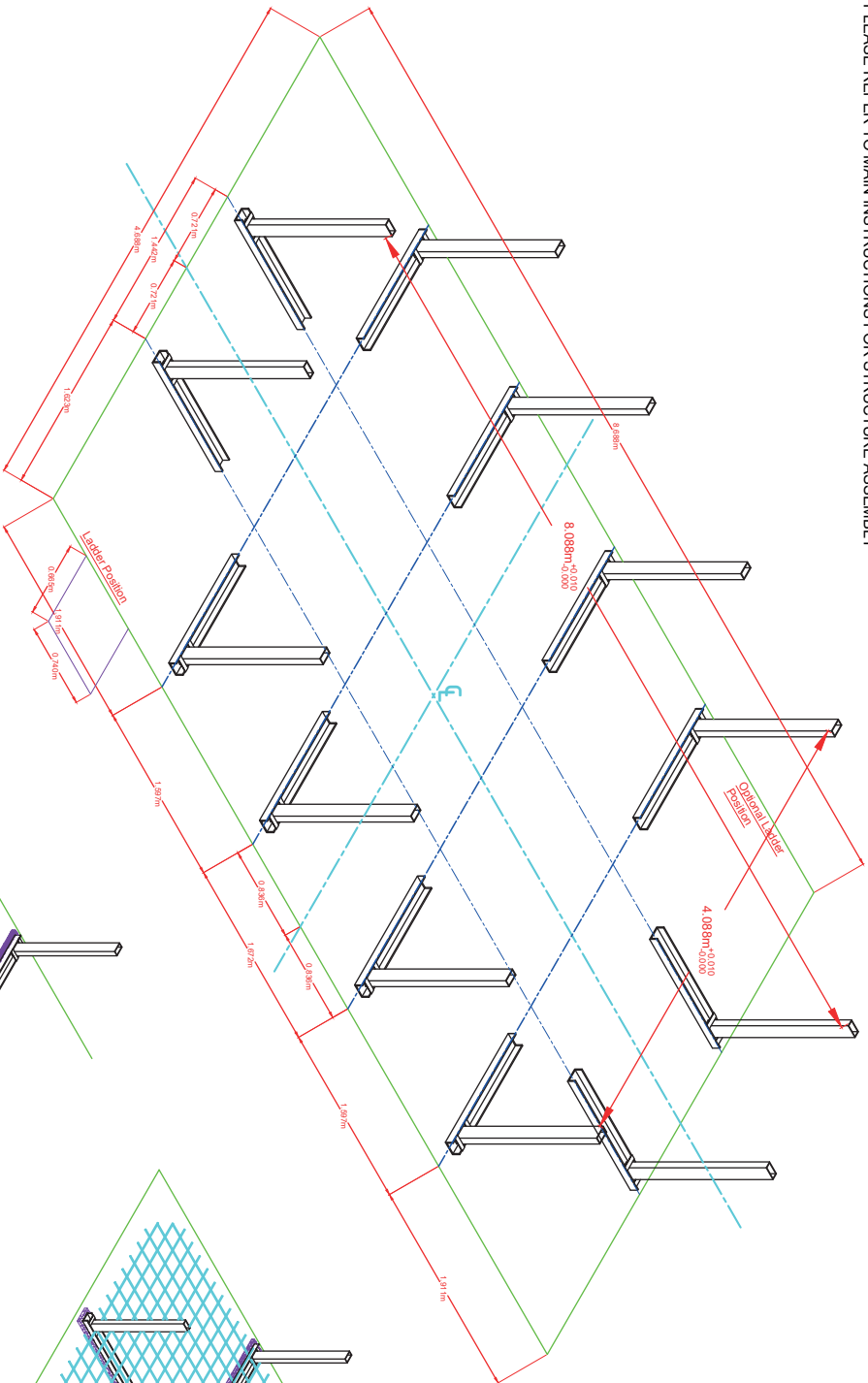

STAGE 2  
Lay reinforced mesh on top of brace

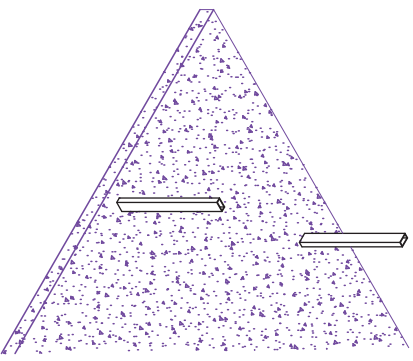

STAGE 3  
When mesh is in position, pour concrete into excavation to cover mesh by 50mm minimum.

STAGE 1  
When happy with brace location(s)  
Set braces on approx 35mm bed of mortar and concrete around brace(s) before the main pour of cement.

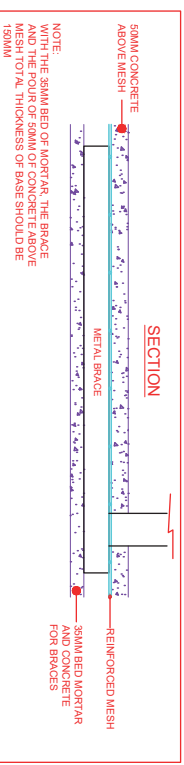

NOTE  
WITH THE 50MM BED OF MORTAR, THE BRACE AND THE POUR OF 50MM OF CONCRETE ABOVE MESH TOTAL THICKNESS OF BASE SHOULD BE 150MM

# NAZCA 8m x 2m Plan

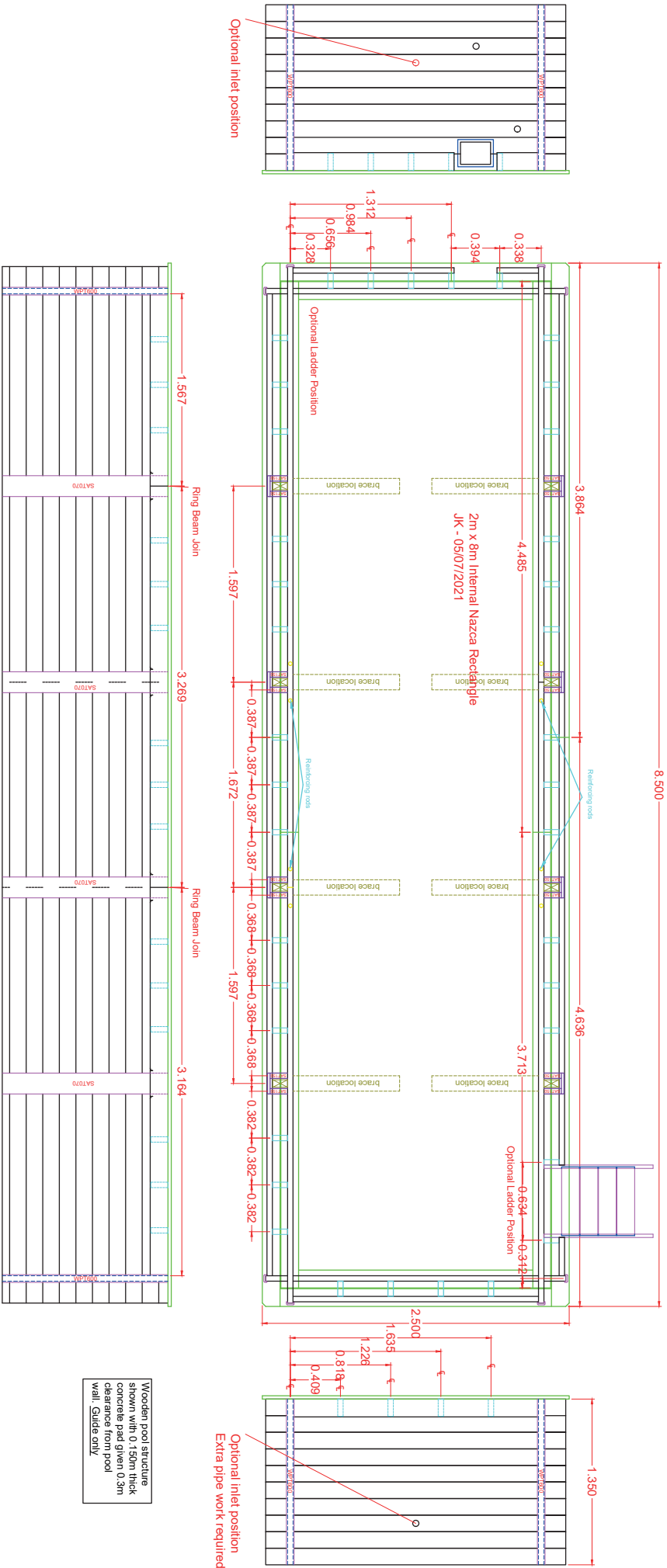

# NAZCA 8m x 2m Brace position plan

BASE LAYOUT DETAILS FOR 8m x 2m Nazca WOODEN POOL  
 ISSUE 1 - JK 09/07/2021 PLEASE REFER TO MAIN INSTRUCTIONS FOR  
 STRUCTURE ASSEMBLY

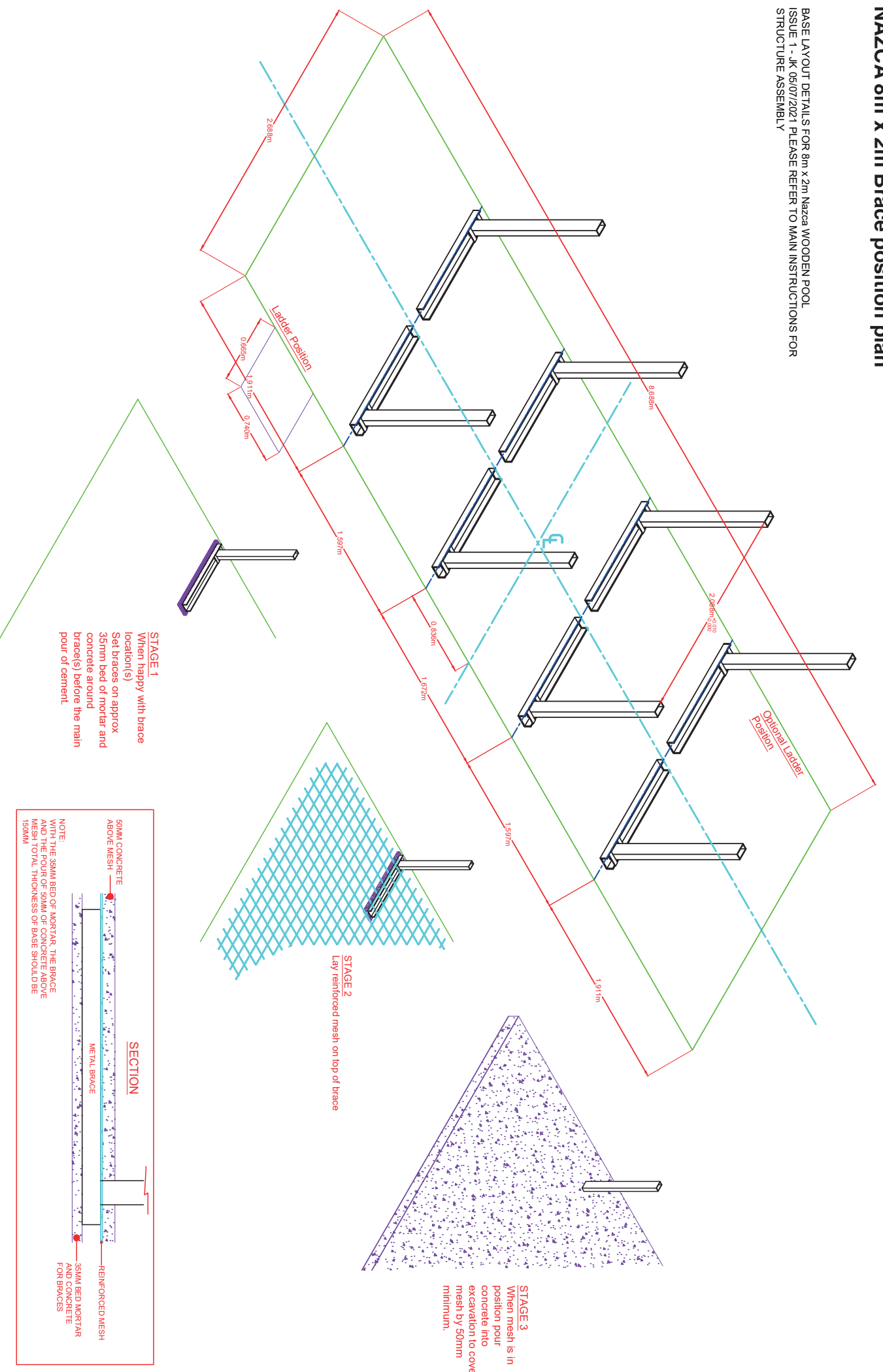

**STAGE 1**  
 When happy with brace location(s)  
 Set braces on approx 35mm bed of mortar and brace(s) before the main pour of cement.

**STAGE 2**  
 Lay reinforced mesh on top of brace

**STAGE 3**  
 When mesh is in position pour concrete into excavation to cover mesh by 50mm minimum.

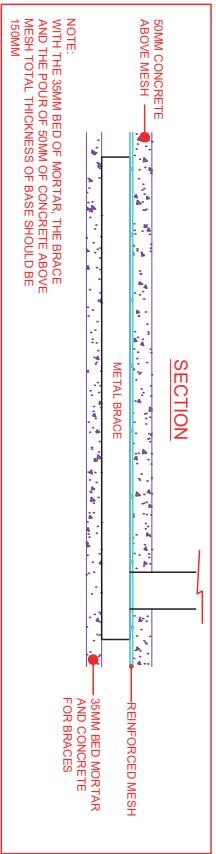

# NAZCA 6m x 4m Plan

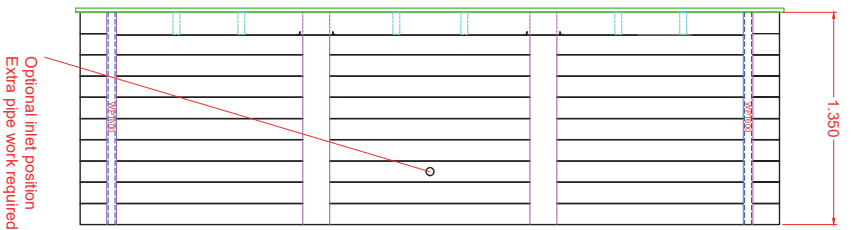
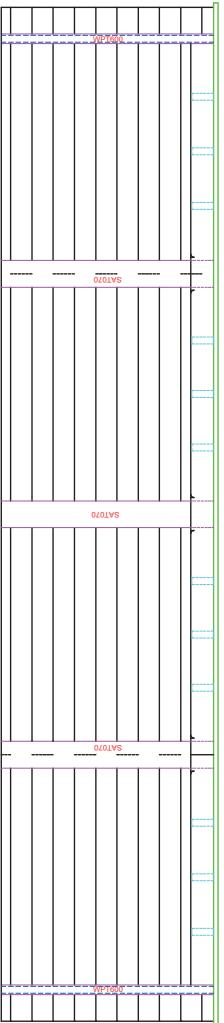
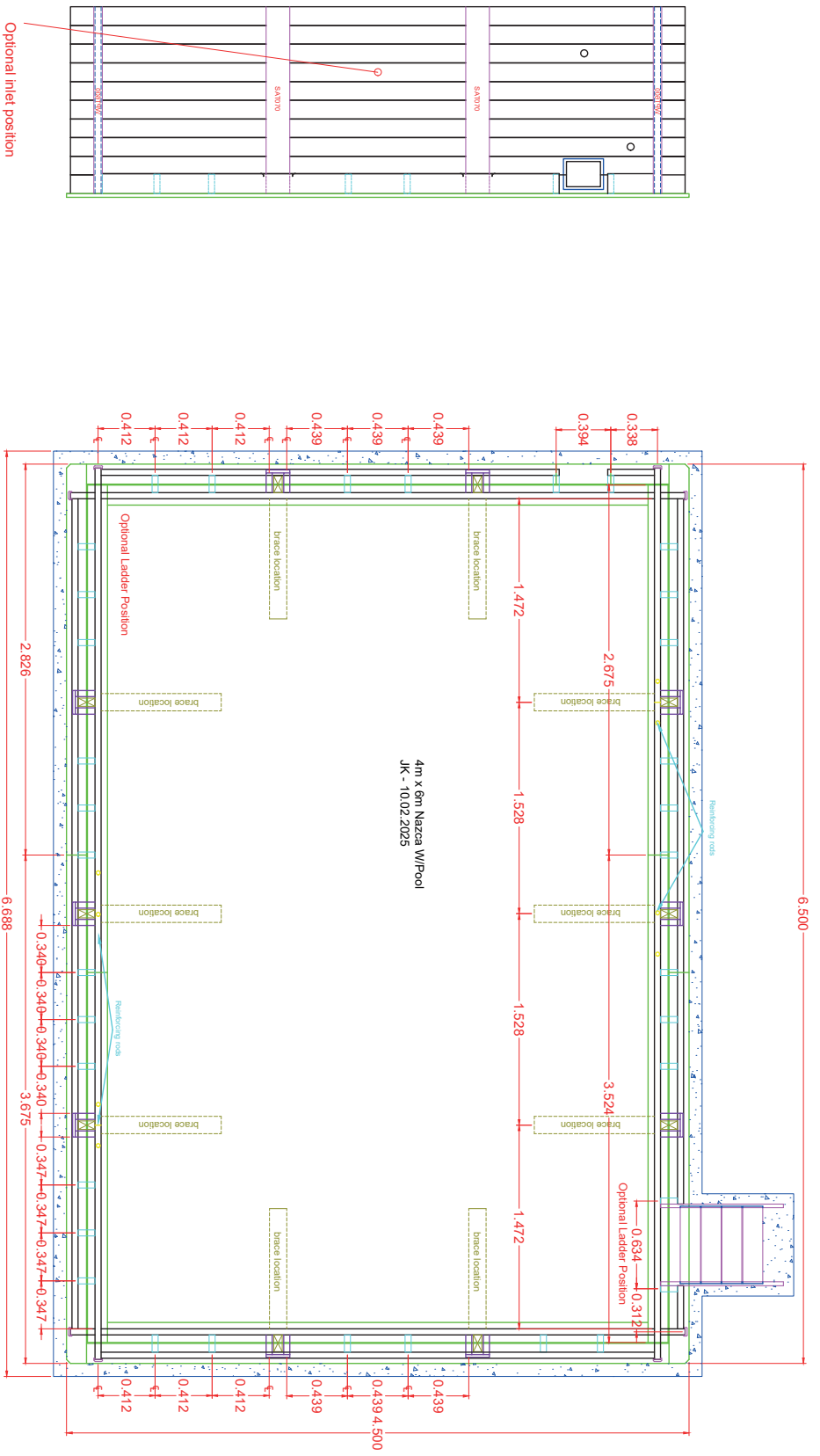

Wooden pool structure shown with 0.150m thick concrete pad given 0.3m clearance from pool wall. Guide only

# NAZCA 6m x 4m Brace position plan

BASE LAYOUT DETAILS FOR 6m x 4m Nazca WOODEN POOL  
 ISSUE 1 - JK 10/02/2025  
 PLEASE REFER TO MAIN INSTRUCTIONS FOR STRUCTURE ASSEMBLY

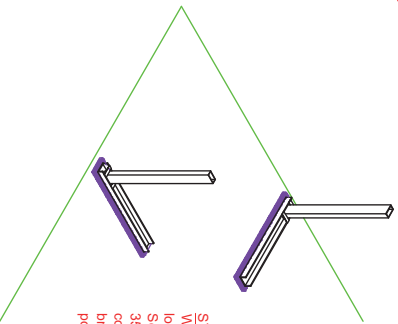
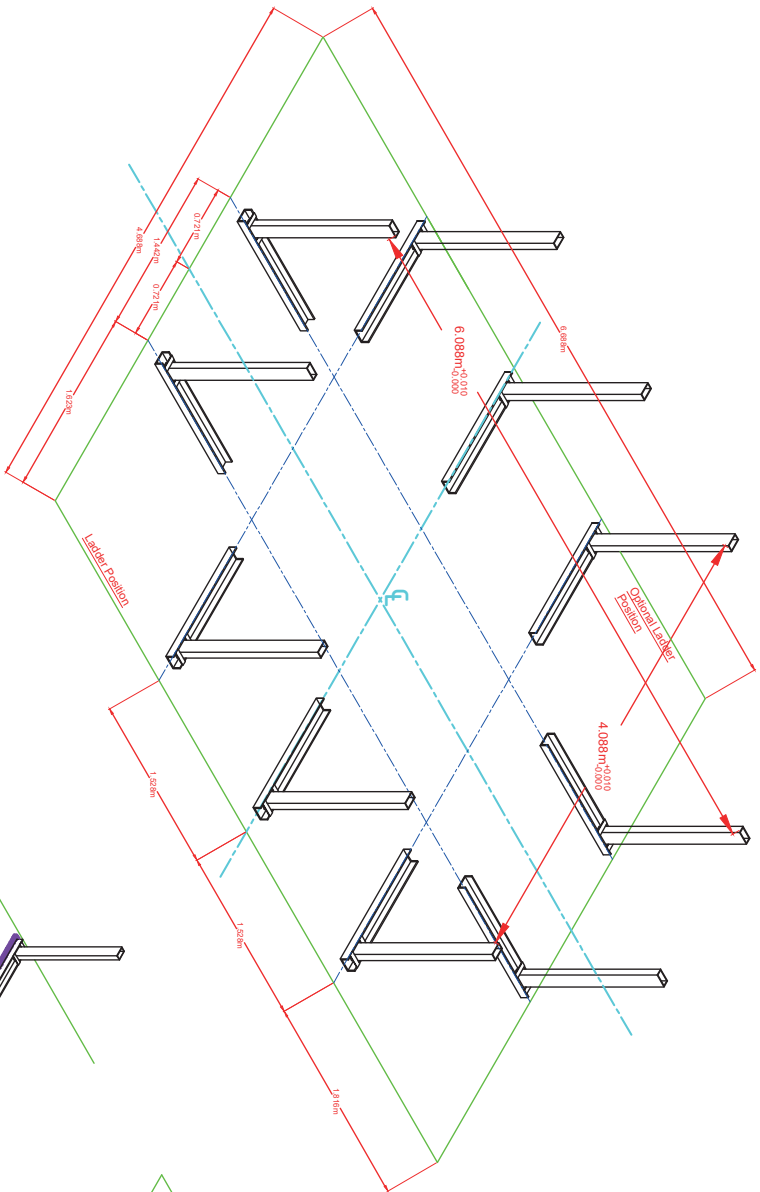

**STAGE 1**  
 When happy with brace location(s)  
 Set braces on approx 3mm bed of mortar and concrete around brace(s) before the main pour of cement.

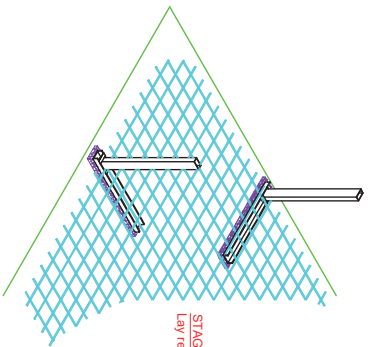

**STAGE 2**  
 Lay reinforced mesh on top of brace

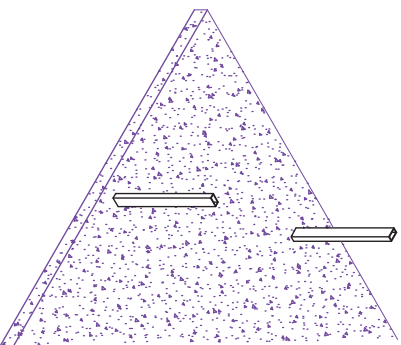

**STAGE 3**  
 When mesh is in position pour concrete into excavation to cover mesh by 50mm minimum.

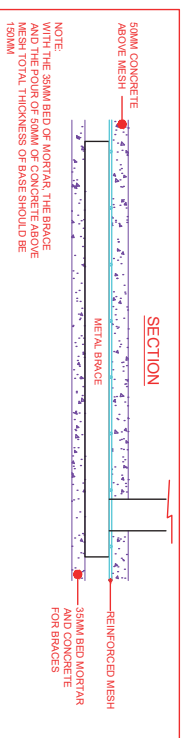

# NAZCA 6m x 3m Plan

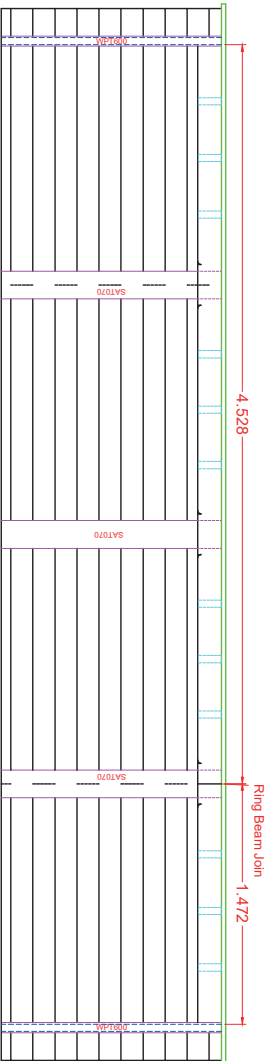
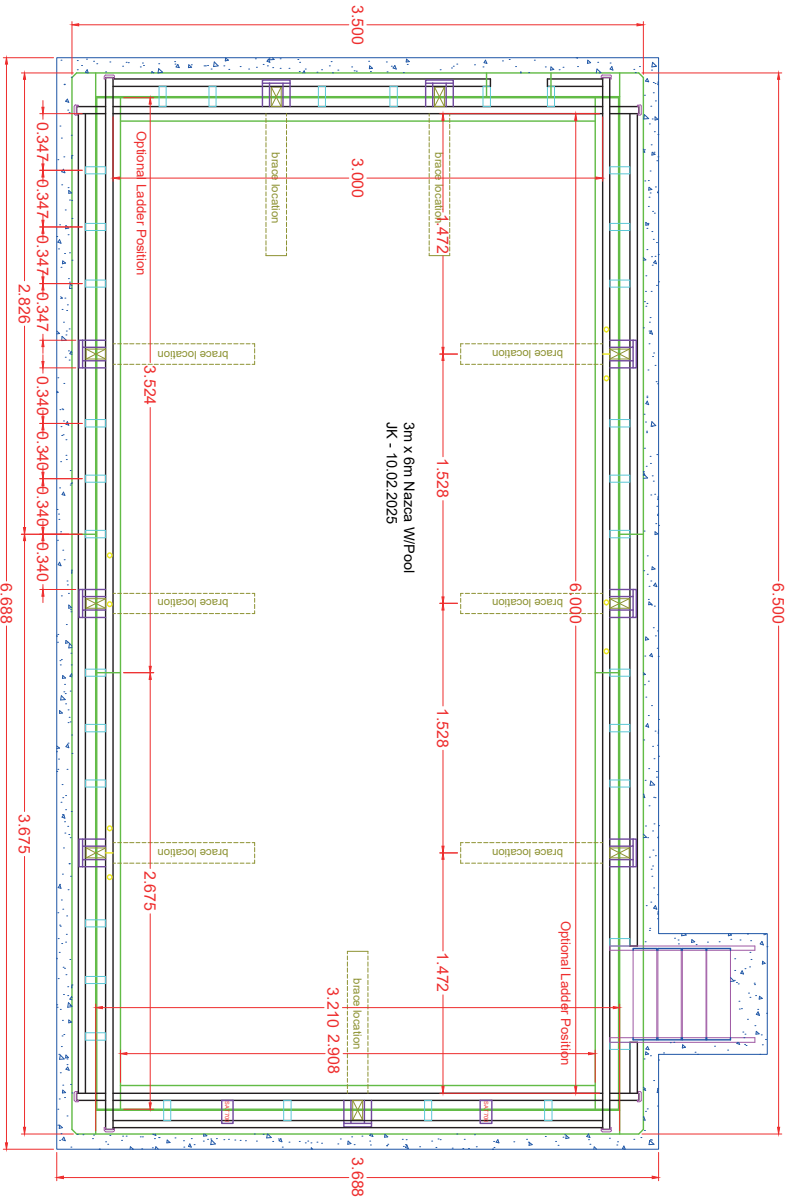
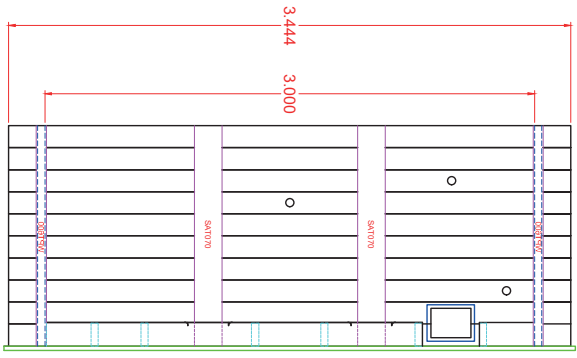

Wooden pool structure shown with 0.150m thick concrete pad given 0.3m clearance from pool wall. Guide only

# NAZCA 6m x 3m Brace position plan

BASE LAYOUT DETAILS FOR 6M x 3M NAZCA  
 ISSUE 1 - 1/10/2023  
 PLEASE REFER TO MAIN INSTRUCTIONS FOR STRUCTURE ASSEMBLY

CONCRETE BASE 6.688M X 3.688M

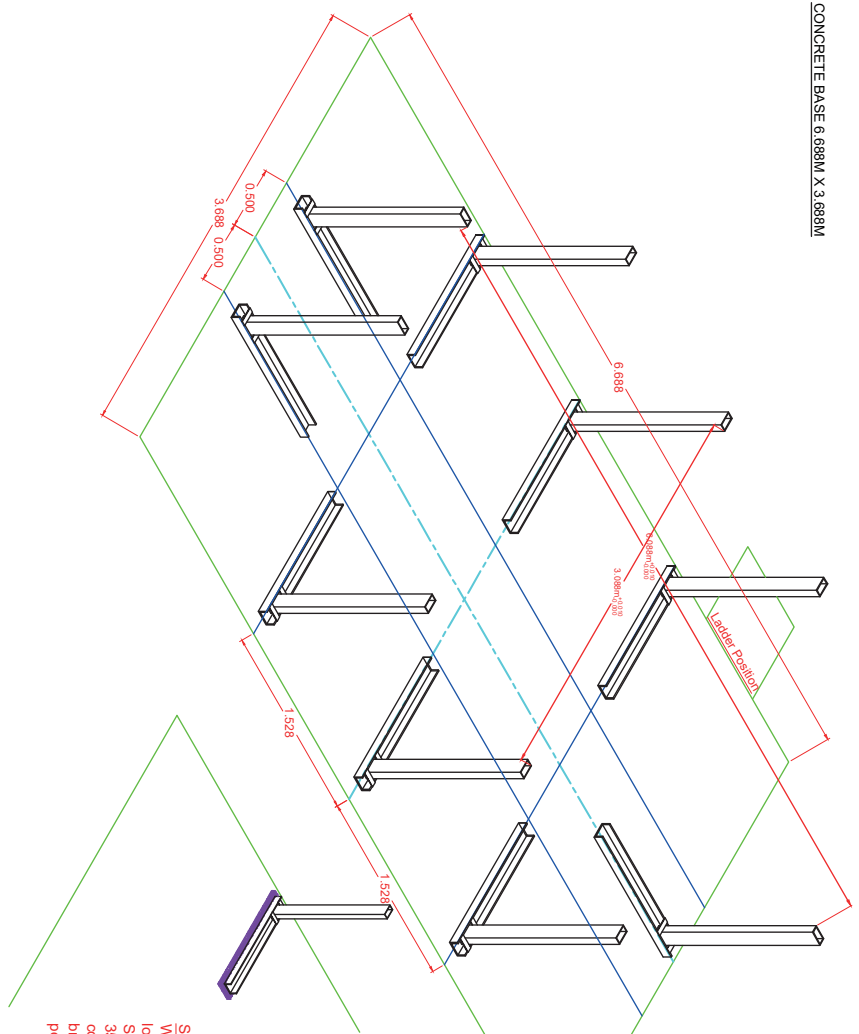

**STAGE 1**  
 When happy with brace location(s)  
 Set braces on approx 38mm bed of mortar and concrete around brace(s) before the main pour of cement.

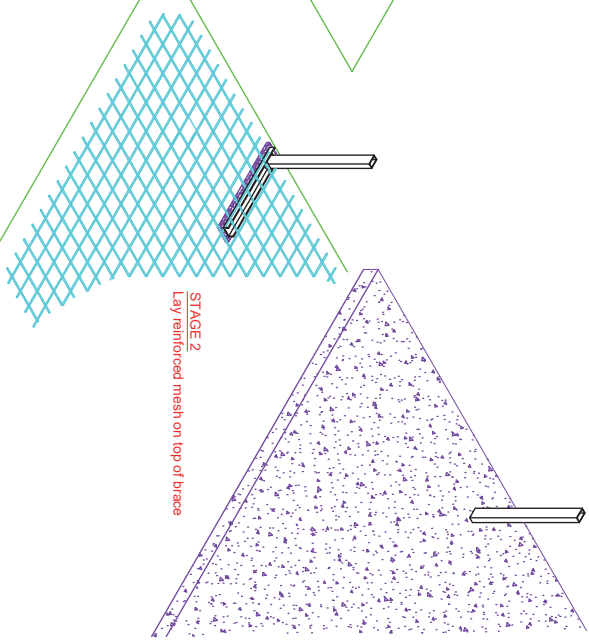

**STAGE 2**  
 Lay reinforced mesh on top of brace

**STAGE 3**  
 When mesh is in position pour concrete into excavation to cover mesh by 50mm minimum.

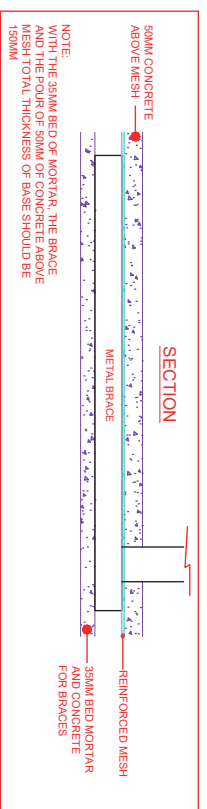



The UK's Leading Independent Swimming Pool Manufacturer and Distributor



[www.woodenpools.net](http://www.woodenpools.net)



[sales@woodenpools.net](mailto:sales@woodenpools.net)

Find us on

